

MODEL SQD

DIRECT DRIVE SQUARE INLINE CENTRIFUGAL DUCT FAN



MODEL FEATURES

- Exhaust air up to 2,800 CFM in high static pressure applications up to 1"
- Direct drive units have low sound levels and quiet operation
- Ideal for applications where space is limited
- Non-overloading backward inclined wheel for efficiency at higher static pressures
- AMCA Air and Sound Licensed
- UL 705 Listed

MODEL OVERVIEW

Model SQD fans are available in sizes 6 through 15, moving up to 2,800 CFM, with static pressure capabilities to 1". SQD units are the perfect selection for clean air applications where space is a leading consideration. The compact housing with removable access doors can be mounted in any orientation.

CONSTRUCTION FEATURES AND OPTIONS

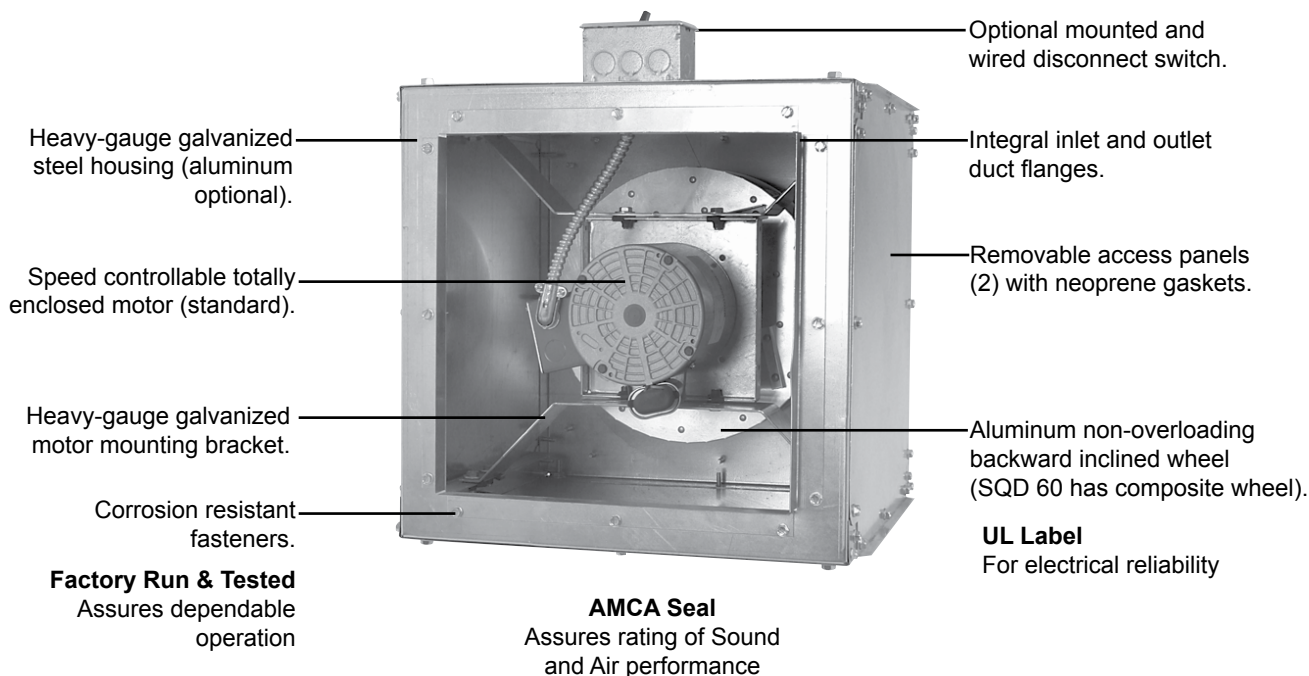

Model SQD is available in our Quickship program. Sizes 6-15 are available for next day, 3-day or 10-day shipping from stock.



1 year fan housing warranty, 1 year motor warranty

All specifications are subject to change without notice unless approved in submittal by JencoFan.



CONSTRUCTION/SPECIFICATION CHECKLIST

Blower/Housing

- Aluminum, non-overloading, backward inclined centrifugal wheel statically and dynamically balanced. SQD 60 has composite wheel.
- Deep spun venturi inlet.
- Heavy-gauge galvanized steel housing.
- Integral inlet and outlet duct collars.
- Universal mounting - horizontal, vertical, or any angle.
- Easy access to interior of unit with removable side panels with closed cell neoprene gasketing.
- Motor and wheel removable from unit without disconnecting duct.

Speed Controllable Motors

- Brands are nationally recognized and locally serviced.
- Standard motors are single speed, speed controllable and totally enclosed.
- All motors are rated for continuous duty.
- Disconnect is standard with totally enclosed motors.
- Motors ship mounted as standard.

Certifications

- AMCA - the AMCA Seal on all units assures certified rating of air and sound performance.
- UL - most models are available as listed by Underwriters Laboratories under Standard 705 when specified.



OPTIONS/ACCESSORIES

Mounted and Wired Disconnect

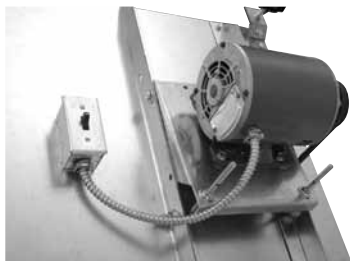

Inlet/Outlet Guard

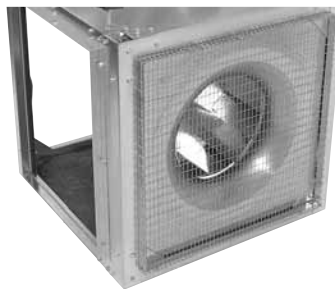

**Hanging Bracket/
Mounting Foot with
Hanging Spring Isolator**



Hanging Spring Isolators



**Hanging Rubber in
Shear Isolators**

Backdraft Damper



Insulated Housing



Assorted Disconnects

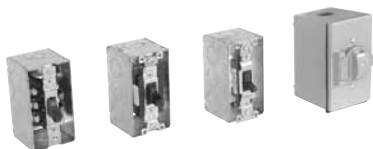

Speed Controls





PERFORMANCE/DIMENSIONS

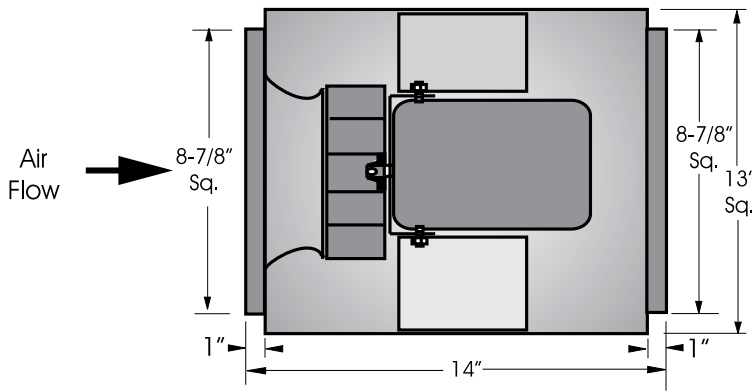

Unit Specifications

- 18 Ga. galvanized housing.
- Approximate unit weight 30 lbs.
- Aluminum backward inclined wheel. (SQD 60 has composite wheel)
- Removable access panels.
- Integral inlet & outlet duct collars.
- AMCA Licensed Air & Sound.
- Disconnect switch.
- One (1) year warranty.
- Universal/any angle mounting.

SQD 60

Motor HP	CFM / Sones @ Static Pressure								RPM
	0	1/8	1/4	3/8	1/2	5/8	3/4	1	
151	1.9	1.0	-	-	-	-	-	-	950
	199	162	102	-	-	-	-	-	
100 WATT 2700 RPM	3.4	2.5	2.2	-	-	-	-	-	1250
	238	208	174	116	-	-	-	-	
.95 Max Amps @ 115/60/1	4.6	3.7	3.5	3.4	-	-	-	-	1500
	294	269	245	215	170	130	-	-	
	6.6	5.6	5.4	5.3	5.2	5.1	-	-	1850
	334	312	290	268	240	201	158	-	
	8.1	7.1	6.8	6.7	6.6	6.5	6.5	-	2100
	382	362	343	324	304	281	250	176	
	10.1	9.2	8.6	8.5	8.5	8.4	8.3	8.3	2400
	424	406	389	372	355	337	316	257	
	12.0	11.1	10.4	10.3	10.2	10.2	10.1	10.0	2700*

SQD 610

Motor HP	CFM / BHP / Sones @ Static Pressure					RPM
	0	1/8	1/4	3/8	1/2	
198	.01/2.3	.01/1.8	-	-	-	950
	229	158	-	-	-	
110 HP 1550 RPM	.01/3.3	.01/3.0	-	-	-	1100
	260	200	115	-	-	
	.01/4.8	.01/4.6	.01/4.1	-	-	1250
	291	239	174	-	-	
	.01/5.8	.01/5.6	.01/5.2	-	-	1400
	322	276	222	150	-	
	.02/6.8	.02/6.7	.02/6.3	.02/5.9	-	1550
	343	300	251	190	-	
	.02/7.5	.02/7.3	.02/7.1	.02/6.7	-	1650
	357	316	269	214	137	
	.03/8.0	.03/7.8	.03/7.6	.02/7.2	.02/6.8	1710*



JencoFan, Div. of Soler & Palau Ventilation Group, certifies that the Models SQD shown herein are licensed to bear the AMCA Seal. The ratings shown are based on test and procedures performed in accordance with AMCA Publication 211 and AMCA Publication 311 and comply with the requirement of the AMCA Certified Ratings Program.



* Base Unit-AMCA seal for sound Rating does not apply to units with speed control installed.
+ RPM range capable with solid state speed control.
Speed (RPM) shown is nominal. Performance is based on actual speed of test.

Performance certified is for installation type B - free inlet, ducted outlet.
Power Ratings (BHP) does not include drive losses.
Performance ratings do not include the effects of appurtenances in the airstream.

The sound ratings shown are loudness values in fan sones @ 5' (1.5m) in a hemispherical free field calculated per AMCA Standard 301. Values shown are for installation type A - free inlet fan sone levels.

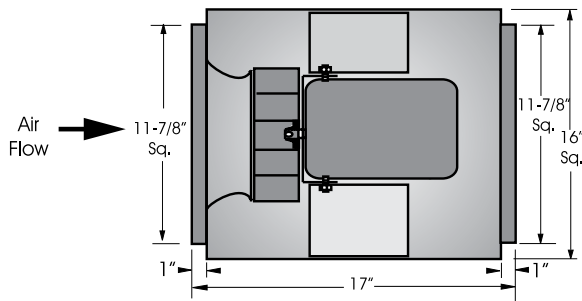

Unit Specifications

- 18 Ga. galvanized housing.
- Approximate unit weight 60 lbs.
- Aluminum backward inclined wheel.
- Removable access panels.
- Integral inlet & outlet duct collars.
- AMCA Licensed Air & Sound.
- Disconnect switch.
- One (1) year warranty.
- Universal/any angle mounting.

SQD 8125

Motor HP	CFM / BHP / Sones @ Static Pressure			RPM
	0	1/8	1/4	
1/25 HP 1050 RPM	329	149	-	700
	.01/1.6	.01/1.0	-	
	376	235	-	800
	.01/2.5	.02/1.8	-	
	423	304	-	900
	.02/3.3	.02/2.7	-	
	446	336	164	950
	.03/3.8	.03/3.1	.02/2.7	
	470	336	221	1000
	.03/4.2	.03/3.6	.03/3.1	
	493	396	267	1050
	.03/4.7	.03/4.1	.03/3.6	
	503	407	284	1070*
	.04/4.9	.04/4.3	.04/3.8	

SQD 825

Motor HP	CFM / BHP / Sones @ Static Pressure							RPM
	0	1/8	1/4	3/8	1/2	5/8	3/4	
1/4 HP 1625 RPM	352	202	-	-	-	-	-	750
	.01/2.2	.01/1.6	-	-	-	-	-	
	423	308	-	-	-	-	-	900
	.03/3.4	.03/2.8	-	-	-	-	-	
	493	398	276	-	-	-	-	1050
	.04/4.7	.04/4.1	.04/3.8	-	-	-	-	
	564	482	388	259	-	-	-	1200
	.06/6.4	.06/5.7	.06/5.4	.06/5.1	-	-	-	
	658	588	514	427	313	-	-	1400
	.09/8.3	.09/7.6	.09/7.2	.09/7.0	.09/6.7	-	-	
	728	665	600	528	444	335	-	1550
	.13/9.6	.13/9.0	.13/8.5	.13/8.3	.13/8.0	.13/7.8	-	
	820	763	706	646	580	504	412	1740*
	.18/11.7	.18/11.1	.18/10.5	.18/10.3	.18/10.0	.18/9.8	.18/9.6	

* Base Unit-AMCA seal for sound Rating does not apply to units with speed control installed.
 + RPM range capable with solid state speed control.
 Speed (RPM) shown is nominal. Performance is based on actual speed of test.

Performance certified is for installation type B - free inlet, ducted outlet.
 Power Ratings (BHP) does not include drive losses.
 Performance ratings do not include the effects of appurtenances in the airstream.

The sound ratings shown are loudness values in fan sones @ 5' (1.5m) in a hemispherical free field calculated per AMCA Standard 301. Values shown are for installation type A - free inlet fan sone levels.



JencoFan, Div. of Soler & Palau Ventilation Group, certifies that the Models SQD shown herein are licensed to bear the AMCA Seal. The ratings shown are based on test and procedures performed in accordance with AMCA Publication 211 and AMCA Publication 311 and comply with the requirement of the AMCA Certified Ratings Program.



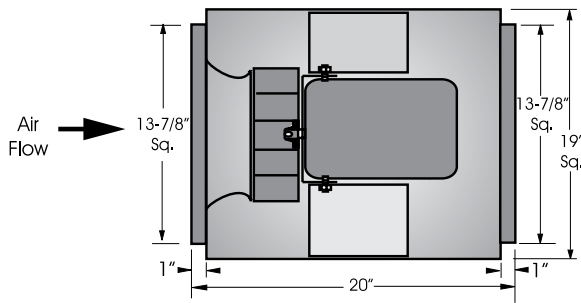

Unit Specifications

- 18 Ga. galvanized housing.
- Approximate unit weight 75 lbs.
- Aluminum backward inclined wheel.
- Removable access panels.
- Integral inlet & outlet duct collars.
- AMCA Licensed Air & Sound.
- Disconnect switch.
- One (1) year warranty.
- Universal/any angle mounting.

SQD 1025

Motor HP	CFM / BHP / Sones @ Static Pressure					RPM
	0	1/8	1/4	3/8	1/2	
1/4 HP 1075 RPM	562	305	-	-	-	600
	.02/2.3	.02/1.5	-	-	-	
	655	451	-	-	-	700
	.04/3.3	.04/2.7	-	-	-	
	749	575	-	-	-	800
	.05/4.5	.05/3.9	-	-	-	
	842	692	514	-	-	900
	.08/5.8	.08/5.2	.08/4.5	-	-	
	936	804	651	434	-	1000
	.10/7.1	.11/6.6	.11/6.0	.10/5.2	-	
983	858	714	547	-	1050	
.12/7.8	.12/7.2	.12/6.8	.12/6.0	-		
1076	964	836	698	473	1150*	
.16/9.2	.16/8.7	.16/8.3	.16/7.7	.16/7.0		

SQD 1050

Motor HP	CFM / BHP / Sones @ Static Pressure								RPM
	0	1/8	1/4	3/8	1/2	5/8	3/4	1	
1/2 HP 1625 RPM	553	292	-	-	-	-	-	-	600
	.02/2.2	.02/1.5	-	-	-	-	-	-	
	738	567	321	-	-	-	-	-	800
	.04/4.2	.04/3.5	.03/3.1	-	-	-	-	-	
	968	845	703	524	-	-	-	-	1050
	.08/7.1	.09/6.4	.09/6.0	.08/5.6	-	-	-	-	
	1106	1000	883	748	584	-	-	-	1200
	.13/9.1	.13/8.5	.13/8.1	.13/7.7	.12/7.3	-	-	-	
	1245	1151	1050	940	815	667	-	-	1350
	.18/11.0	.19/10.5	.19/10.1	.19/9.6	.18/9.3	.18/8.9	-	-	
1337	1250	1158	1058	949	826	680	-	1450	
.22/12.3	.23/11.7	.23/11.2	.23/10.9	.23/10.6	.22/10.2	.21/9.9	-		
1521	1445	1366	1283	1194	1098	993	740	1650	
.33/15.2	.34/14.5	.34/13.9	.34/13.6	.34/13.2	.34/12.9	.33/12.6	.31/12.0		
1578	1505	1430	1350	1266	1175	1078	852	1710*	
.37/16.2	.38/15.4	.38/14.7	.38/14.4	.38/14.1	.38/13.8	.38/13.5	.36/13.0		

* Base Unit-AMCA seal for sound Rating does not apply to units with speed control installed.
 + RPM range capable with solid state speed control.
 Speed (RPM) shown is nominal. Performance is based on actual speed of test.

Performance certified is for installation type B - free inlet, ducted outlet.
 Power Ratings (BHP) does not include drive losses.
 Performance ratings do not include the effects of appurtenances in the airstream.

The sound ratings shown are loudness values in fan sones @ 5' (1.5m) in a hemispherical free field calculated per AMCA Standard 301. Values shown are for installation type A - free inlet fan sone levels.



JencoFan, Div. of Soler & Palau Ventilation Group, certifies that the Models SQD shown herein are licensed to bear the AMCA Seal. The ratings shown are based on test and procedures performed in accordance with AMCA Publication 211 and AMCA Publication 311 and comply with the requirement of the AMCA Certified Ratings Program.



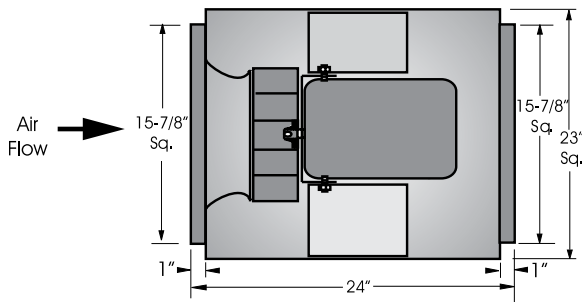

Unit Specifications

- 18 Ga. galvanized housing.
- Approximate unit weight 90 lbs.
- Aluminum backward inclined wheel.
- Removable access panels.
- Integral inlet & outlet duct collars.
- AMCA Licensed Air & Sound.
- Disconnect switch.
- One (1) year warranty.
- Universal/any angle mounting.

SQD 1225

Motor HP	CFM / BHP / Sones @ Static Pressure					RPM
	0	1/8	1/4	3/8	1/2	
1/4 HP 1075 RPM	920	599	-	-	-	650
	.04/3.7	.04/3.0	-	-	-	
	1132	878	595	-	-	800
	.07/5.7	.07/5.0	.07/4.4	-	-	
	1273	1051	809	529	-	900
	.10/7.2	.10/6.5	.10/6.0	.09/5.2	-	
	1415	1216	1003	774	-	1000
	.13/8.8	.13/8.1	.13/7.6	.13/7.0	-	
	1486	1297	1096	883	640	1050
	.15/9.6	.15/9.0	.16/8.4	.15/7.9	.15/7.2	
1557	1377	1187	986	767	1100	
.17/10.5	.18/9.9	.18/9.3	.18/8.8	.17/8.1		
1586	1410	1224	1028	817	1120*	
.18/10.9	.19/10.3	.19/9.7	.19/9.2	.19/8.5		

SQD 1250

Motor HP	CFM / BHP / Sones @ Static Pressure								RPM
	0	1/8	1/4	3/8	1/2	5/8	3/4	1	
1/2 HP 1625 RPM	867	500	-	-	-	-	-	-	600
	.02/3.0	.03/2.4	-	-	-	-	-	-	
	1156	882	592	-	-	-	-	-	800
	.06/5.4	.06/4.8	.06/4.4	-	-	-	-	-	
	1373	1129	920	654	-	-	-	-	950
	.10/7.3	.11/6.8	.11/6.4	.10/6.1	-	-	-	-	
	1517	1287	1106	890	651	-	-	-	1050
	.13/8.7	.14/8.2	.15/7.8	.15/7.4	.14/7.2	-	-	-	
	1878	1673	1526	1380	1215	1020	825	-	1300
	.25/12.7	.26/12.2	.27/11.9	.28/11.5	.28/11.2	.28/10.8	.26/10.5	-	
2168	1975	1844	1719	1591	1451	1292	950	1500	
.39/16.4	.40/16.0	.41/15.6	.42/15.2	.43/14.9	.44/14.6	.43/14.3	.40/13.7		
2344	2159	2033	1918	1802	1680	1548	1237	1620*	
.49/18.4	.50/18.0	.51/17.7	.53/17.3	.54/16.9	.55/16.7	.55/16.4	.54/15.8		

* Base Unit-AMCA seal for sound Rating does not apply to units with speed control installed.
 + RPM range capable with solid state speed control.
 Speed (RPM) shown is nominal. Performance is based on actual speed of test.

Performance certified is for installation type B - free inlet, ducted outlet.
 Power Ratings (BHP) does not include drive losses.
 Performance ratings do not include the effects of appurtenances in the airstream.

The sound ratings shown are loudness values in fan sones @ 5' (1.5m) in a hemispherical free field calculated per AMCA Standard 301. Values shown are for installation type A - free inlet fan sone levels.



JencoFan, Div. of Soler & Palau Ventilation Group, certifies that the Models SQD shown herein are licensed to bear the AMCA Seal. The ratings shown are based on test and procedures performed in accordance with AMCA Publication 211 and AMCA Publication 311 and comply with the requirement of the AMCA Certified Ratings Program.



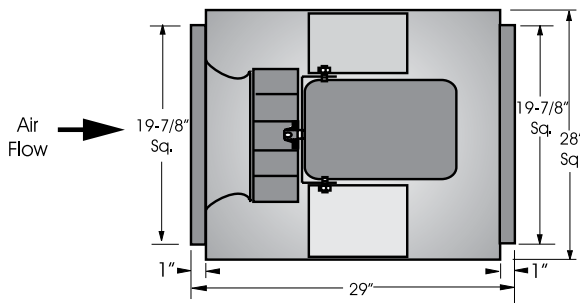

Unit Specifications

- 18 Ga. galvanized housing.
- Approximate unit weight 120 lbs.
- Aluminum backward inclined wheel.
- Removable access panels.
- Integral inlet & outlet duct collars.
- AMCA Licensed Air & Sound.
- Disconnect switch.
- One (1) year warranty.
- Universal/any angle mounting.

SQD 1550

Motor HP	CFM / BHP / Sones @ Static Pressure							RPM
	0	1/8	1/4	3/8	1/2	5/8	3/4	
1/2 HP 1075 RPM	1348	847	-	-	-	-	-	500
	.05/3.8	.05/3.1	-	-	-	-	-	
	1618	1187	797	-	-	-	-	600
	.09/5.5	.09/4.8	.08/4.3	-	-	-	-	
	1887	1517	1174	793	-	-	-	700
	.14/7.2	.14/6.6	.14/6.1	.12/5.8	-	-	-	
	2157	1839	1515	1233	833	-	-	800
	.22/9.2	.22/8.6	.21/8.0	.20/7.7	.18/7.4	-	-	
	2426	2152	1849	1585	1335	994	-	900
	.31/11.5	.31/10.8	.31/10.2	.30/9.8	.29/9.5	.26/9.2	-	
2696	2456	2178	1924	1695	1469	1187	1000	
.42/14.0	.42/13.4	.42/12.7	.42/12.2	.41/11.8	.39/11.5	.37/11.2		
2879	2658	2399	2151	1928	1719	1501	1060*	
.51/15.8	.51/15.2	.51/14.6	.51/14.1	.51/13.7	.49/13.3	.47/13.0		

* Base Unit-AMCA seal for sound Rating does not apply to units with speed control installed.
+ RPM range capable with solid state speed control.
Speed (RPM) shown is nominal. Performance is based on actual speed of test.

Performance certified is for installation type B - free inlet, ducted outlet.
Power Ratings (BHP) does not include drive losses.
Performance ratings do not include the effects of appurtenances in the airstream.

The sound ratings shown are loudness values in fan sones @ 5' (1.5m) in a hemispherical free field calculated per AMCA Standard 301. Values shown are for installation type A - free inlet fan sone levels.



JencoFan, Div. of Soler & Palau Ventilation Group, certifies that the Models SQD shown herein are licensed to bear the AMCA Seal. The ratings shown are based on test and procedures performed in accordance with AMCA Publication 211 and AMCA Publication 311 and comply with the requirement of the AMCA Certified Ratings Program.

