

## MODELS FF & FFC CEILING AND INLINE/CABINET VENTILATORS



**Model FF**

The extremely quiet FF and FFC ventilators are available from 50 to 3600 CFM, with static pressure capabilities to 1". All units have centrifugal blower wheels (except FF50 and FF50E) and low RPM motors on resilient mounts (except FF50, FF50E and FF80). These units are used to exhaust air from a variety of commercial and institutional applications, such as restrooms, conference rooms, offices, storage areas, restaurants, retail stores, schools, and similar buildings...anywhere quiet, high-capacity ventilation is needed.



**Model FFC**

The forward curved centrifugal wheel with its high static pressure capability makes these ventilators suitable for either ducted or nonducted applications. They include removable blower assemblies and plug-in permanently lubricated motors for ease of servicing and cleaning.

A complete selection of accessories including speed controls, wall and roof caps, duct transitions, inline adaptors, metal grille kits and radiation dampers simplify installation.

**Most of our line of FF and FFC fans are in-stock available for next day shipment!**



### Features

#### Grille

- Conceals interior.
- Low profile styling, blends with any decor.
- White polymeric (FF50 - FF300).
- Metal finished with white enamel finish (FF400-FF1500).

#### Blower

- Low RPM for quiet operation, speed controllable.
- Resilient anti-vibration mounts (FF50, FF50E & FF80 rigid mount).
- Balanced, polymeric, centrifugal blower wheel for quiet, efficient performance. (Metal wheel on FFC2000 & FFC3500).
- Permanently lubricated, thermally protected motor.
- Plug-in motor.
- Designed for continuous operation.

#### Housing

- Rugged, 20 gauge galvanized steel.
- Duct connector.
- 1/2" acoustic insulation inside (except FF50, FF80 & FFC's).
- Integral automatic backdraft damper.

- Easy inline conversion available (FF100-FF1500).
- May be installed in ceiling or wall.
- Mounting brackets for easy installation and adaptability to numerous mounting requirements.
- Factory-shipped in horizontal discharge position, easily converted to vertical discharge.
- FFC inline units have a removable panel which allows for easy motor access without disturbing ductwork.

#### AMCA Seal

- AMCA Air and Sound Licensed

#### UL Label

- cULus listed (except FF50 & FF80 which are UL only).



JencoFan, Div. of Soler & Palau Ventilation Group, certifies that the Models FF/FFC shown herein are licensed to bear the AMCA Seal. The ratings shown are based on test and procedures performed in accordance with AMCA Publication 211 and AMCA Publication 311 and comply with the requirement of the AMCA Certified Ratings Program.



**1 year fan housing warranty, 1 year motor warranty**

## Options/Accessories

### Roof Cap and Wall Cap

- Weather resistant duct termination.

### Inline Adapter Kit

- Converts FF units into inline units.
- Available for FF100 through FF1500

### Radiation Damper

- UL rated for use in 1, 2, or 3 hour rated floor-ceiling, roof-ceiling design.
- Mounts directly to the fan, screws provided.
- Galvanized steel frame.
- High temperature, non-asbestos, reinforced fiber thermal fabric.
- 212°F fusible link.
- Stainless steel negator-type closure spring.
- Available for FF100 through FF1500.

### Metal Grille Kit

- White enamel painted steel.
- Mounting screws included.
- Available for FF100, FF300, FFC2000 and FFC3500.

### Duct Transition

- Allows for quick transition to round ducting.
- Galvanized steel construction.

### Vibration Dampening Hangers

- Rubber in shear.
- Heavy-gauge steel construction with neoprene vibration dampening cushion.
- For use with 3/8" threaded rod (by others).

### Damper Kit (for FFC 2000 and FFC 3500)

- Twin damper flaps and mounting hardware.
- Foam cushion and magnetic catch assure quiet backdraft prevention.

## TYPICAL SPECIFICATIONS

### FF50, FF50E & FF80

Ventilator shall have galvanized steel housing with double-strength mounting flanges. It shall be ducted vertically (horizontally) to a roof cap (wall cap).

Motor assembly shall be removable and permanently lubricated.

Air delivery shall be no less and sound levels no greater than listed. All air and sound ratings shall be certified by AMCA. Units shall be U.L. listed.

### FF100 - FF1500

Ventilator shall have galvanized steel housing insulated with at least 1/2" of acoustic insulation. Housing to have adjustable mounting brackets.

Automatic backdraft damper to be located within duct connector. Duct connector, blower assembly and wiring plate shall be adjustable for either horizontal or vertical installation.

Blower assembly shall be removable from installed housing and will have a polymeric, dynamically balanced centrifugal-type blower wheel. Motor to be permanently lubricated and mounted with resilient anti-vibration mounts. RPM not to exceed number listed for each model.

Air delivery shall be no less and sound levels no greater than listed for each model. All air and sound ratings shall be certified by AMCA. Units to be cULus listed.

### FFC100 - FFC 1500

Ventilator shall have galvanized steel housing. Housing to have adjustable mounting brackets and removable panel to allow access to motor without disturbing ductwork.

Automatic backdraft damper to be located within duct connection. Duct connector, blower assembly and wiring plate shall be adjustable for either horizontal or vertical installation.

Blower unit shall be removable from housing and will have a polymeric, dynamically balanced centrifugal-type blower wheel. Motor to be permanently lubricated and mounted with resilient anti-vibration mounts. RPM not to exceed number listed for each model.

Air delivery shall be no less and sound levels no greater than listed for each model. All air and sound ratings shall be certified by AMCA. Units to be cULus listed.

### FFC2000 & FFC3500

Ventilator shall have galvanized steel housing lined with acoustic insulation. Housing to have adjustable mounting brackets.

Automatic backdraft dampers to be located within duct connector (optional). Duct connector, blower assembly and wiring plate shall be adjustable for either horizontal or vertical installation.

Blower unit shall be removable from housing and will have a metal, centrifugal-type blower wheels. Motor to be permanently lubricated and mounted with resilient anti-vibration mounts. RPM not to exceed number listed for each model.

Air delivery shall be no less and sound levels no greater than listed for each model. All air and sound ratings shall be certified by AMCA. Units to be cULus listed.

All specifications are subject to change without notice unless approved in submittal by JencoFan.

# MODEL FF PERFORMANCE

## FF CEILING VENTILATORS

MODEL FF	CFM / Sones at Static Pressure (PS - Inches of H <sub>2</sub> O)										AMPS @ 60HZ/ WATTS	RPM @ 1/8	Voltage	Average Ship Wt. Lbs
	0	1/10	1/8	1/4	3/8	1/2	5/8	3/4	7/8	1				
100	136 0.5	115 0.8	109 0.9	93 1.3	80 1.8	65 2.3	44 3.0	- -	- -	- -	1.1/87	640	120	23
150	181 1.3	161 1.4	157 1.5	141 2.2	132 2.6	124 3.1	114 3.6	94 4.1	62 4.6	-	1.3/100	710	120	23
200	231 1.6	214 1.8	210 1.7	196 2.3	186 2.9	177 3.5	165 4.1	144 4.9	113 5.3	51 5.3	1.8/127	740	120	23
250	272 2.1	261 2.3	259 2.2	250 2.9	242 3.3	233 3.9	218 4.4	201 4.8	165 5.5	99 5.8	2.1/166	830	120	23
300	312 2.8	309 2.9	308 2.9	303 3.3	296 3.5	287 3.9	273 4.3	254 4.7	219 5.1	125 5.6	2.6/212	905	120	23
400	480 2.0	442 2.4	434 2.3	388 2.8	344 3.3	299 3.8	229 4.5	182 4.8	114 5.4	-	1.4/146	735	120	34
500	538 3.0	520 3.1	514 3.3	491 3.6	463 4.0	434 4.4	389 5.0	339 5.7	282 6.2	186 6.7	2.2/232	810	120	34
700	722 4.5	704 4.6	701 4.7	667 4.8	640 5.0	607 5.2	571 5.6	534 6.2	453 7.1	333 7.2	2.9/313	960	120	34
900	918 3.8	905 4.0	901 4.1	877 4.0	842 4.2	793 4.3	725 4.4	636 4.9	536 4.5	390 5.3	3.0/306	650	120	64
1500	1578 8.6	1526 8.4	1513 8.4	1438 8.1	1371 7.5	1285 7.0	1198 6.7	1103 6.2	1000 5.8	816 5.8	5.0/468	955	120	64

## COMPACT FF CEILING VENTILATORS

MODEL FF	CFM / Sones at Static Pressure (PS - Inches of H <sub>2</sub> O)										AMPS @ 60HZ/ WATTS	RPM @ 1/8	Voltage	Average Ship Wt. Lbs
	0	1/10	1/8	1/4	3/8	1/2	5/8	3/4	7/8	1				
50	52 3.9	49 4.3	47 4.4	42 4.6	29 5.5	-	-	-	-	-	0.8/48	1870	120	4
80	89 3.9	81 3.8	80 3.8	68 3.8	36 3.9	-	-	-	-	-	0.75/48	1280	120	7

Performance ratings include the effects of inlet grille and backdraft damper. Speed (RPM) shown is nominal. Performance is based on actual speed of test. The sound ratings shown are loudness values in fan sones at 5' (1.5m) in a hemispherical free field calculated per AMCA Standard 301. Values shown are for installation Type B: free inlet fan sone levels. Performance certified is for installation Type B: Free inlet, Ducted outlet.

## COMPACT FF50E CEILING VENTILATOR

MODEL FF	Volts	Hz	AMPS	CFM	Sones
50E	120	60	.90	50	4.0

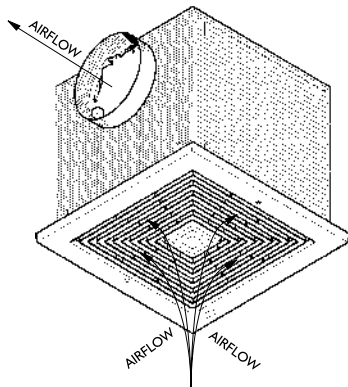

JencoFan, Div. of Soler & Palau Ventilation Group, certifies that the Models FF/FFC shown herein are licensed to bear the AMCA Seal. The ratings shown are based on test and procedures performed in accordance with AMCA Publication 211 and AMCA Publication 311 and comply with the requirement of the AMCA Certified Ratings Program.



# MODEL FFC PERFORMANCE

## FFC INLINE/CABINET VENTILATORS

MODEL FFC	CFM / Sones at Static Pressure (PS - Inches of H <sub>2</sub> O)										AMPS @ 60HZ/ WATTS	RPM @ 1/8	Voltage	Average Ship Wt. Lbs.
	0	1/10	1/8	1/4	3/8	1/2	5/8	3/4	7/8	1				
100	121	108	106	97	93	86	70	44	-	-	1.0/87	760	120	23
	0.5	0.7	0.7	1.1	1.4	1.8	2.1	2.4	-	-				
150	153	148	147	140	134	125	111	91	54	-	1.3/100	920	120	23
	0.9	1.0	1.1	1.4	1.6	1.9	2.1	2.2	2.4	-				
200	205	196	195	190	185	175	158	135	96	47	1.8/127	865	120	23
	1.7	1.9	1.9	2.1	2.3	2.4	3.0	3.3	3.4	3.4				
250	248	245	245	241	235	224	208	183	141	84	2.1/166	1005	120	23
	2.0	2.3	2.3	2.8	2.8	3.2	3.4	3.6	3.9	3.8				
300	300	294	293	285	274	259	243	214	168	113	2.6/212	1145	120	23
	2.9	3.0	3.1	3.3	3.4	3.5	3.6	3.7	4.0	3.9				
400	450	415	406	360	313	271	223	167	90	6.0	1.4/146	775	120	34
	1.4	1.6	1.6	1.9	2.2	2.6	2.9	3.4	3.6	3.9				
500	546	526	519	496	472	447	407	364	306	232	2.2/232	890	120	34
	2.4	2.4	3.4	3.7	3.9	3.8	3.9	4.0	4.3	4.3				
700	704	686	681	656	631	604	575	533	480	412	2.9/313	1090	120	34
	3.6	3.8	3.7	3.9	4.0	4.2	4.3	4.4	4.7	5.0				
900	930	902	894	853	807	754	685	587	442	300	3.0/306	810	120	64
	3.7	3.8	3.8	3.8	3.7	3.8	3.9	4.0	4.0	4.1				
1500	1275	1228	1214	1152	1092	1029	958	871	764	631	5.0/468	1055	120	64
	6.8	6.8	6.7	6.5	6.3	6.0	6.0	6.0	6.0	6.1				

Performance ratings include the effects of backdraft damper. Speed (RPM) shown is nominal. Performances based on actual speed of test. The sound ratings shown are loudness values in fan sones at 5" (1.5m) in a hemispherical free field calculated per AMCA Std. 301. Values shown are for installation Type D: ducted inlet fan sone levels. Ratings do not include the effect of duct end correction. Performance ratings include the effects of 18 feet of round inlet duct and, if needed, a rectangular to round duct transition in the airstream. Performance certified is for Installation Type D; Ducted inlet, Ducted outlet.

## FFC CABINET VENTILATORS

MODEL FFC	CFM / Sones at Static Pressure (PS - Inches of H <sub>2</sub> O)										AMPS @ 60HZ/ WATTS	RPM @ 1/8	Voltage	Average Ship Wt. Lbs.
	0	1/10	1/8	1/4	3/8	1/2	5/8	3/4	7/8	1				
2000	1891	1803	1791	1657	1508	1347	1165	808	-	-	5.8/590	965	120	92
	10.3	9.8	9.4	9.0	8.6	9.1	8.9	7.0	-	-				
3500	3605	3498	3452	3278	3073	2983	2679	2429	2093	1693	5.4/1205	1105	240	139
	15.3	14.8	14.5	14.1	13.1	12.8	12.1	11.8	11.9	10.8				

Performance ratings do not include the effects of appurtenances (accessories). Speed (RPM) shown is nominal. Performance is based on actual speed of test. The sound ratings shown are loudness values in fan sones at 5' (1.5m) in a hemispherical free field calculated per AMCA Std. 301. Values shown are for installation Type D: ducted inlet fan sone levels. Ratings do not include the effect of duct end correction. Performance certified is for Installation Type D: Ducted inlet, Ducted outlet.

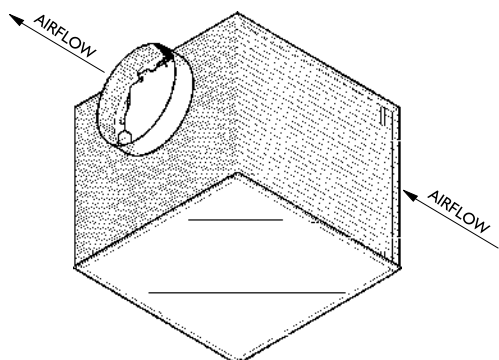

JencoFan, Div. of Soler & Palau Ventilation Group, certifies that the Models FF/FFC shown herein are licensed to bear the AMCA Seal. The ratings shown are based on test and procedures performed in accordance with AMCA Publication 211 and AMCA Publication 311 and comply with the requirement of the AMCA Certified Ratings Program.



# DIMENSIONS

## CEILING VENTILATOR

**FF50 & FF50E**

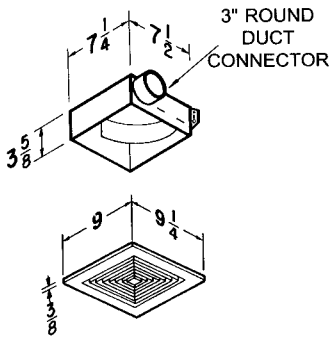

**FF80**

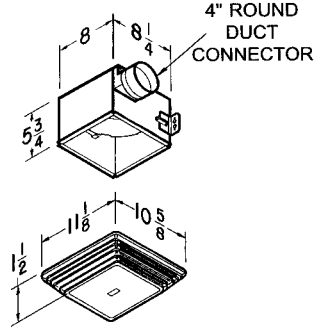

**FF100 & 150**

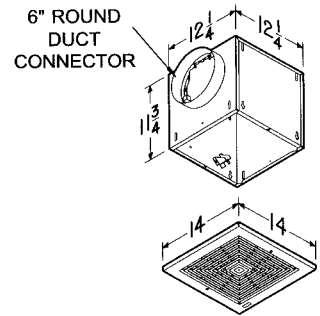

**FF200, 250 & 300**

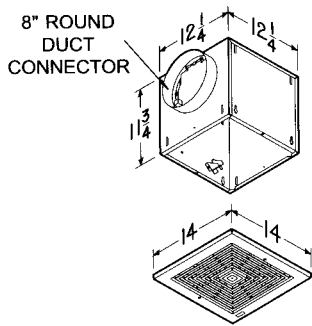

**FF400, 500 & 700**

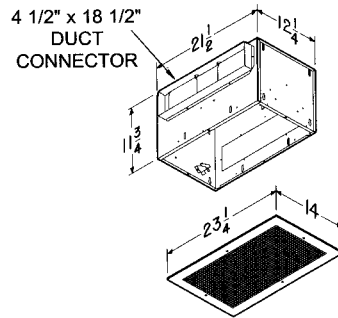

**FF900 & 1500**

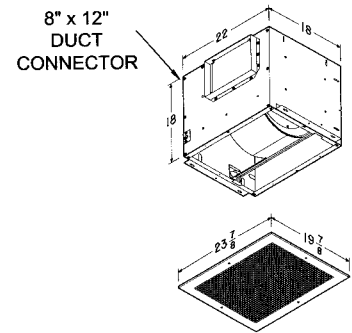

## Inline/Cabinet Ventilator

**FFC100 & 150**

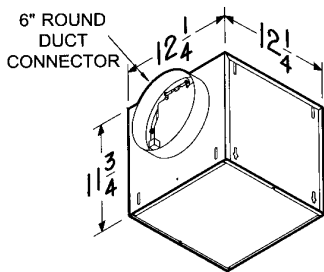

**FFC200, 250 & 300**

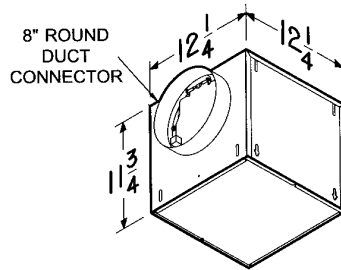

**FFC400, 500 & 700**

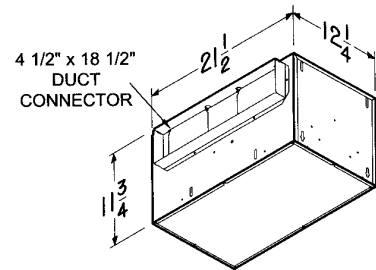

**FFC900 & 1500**

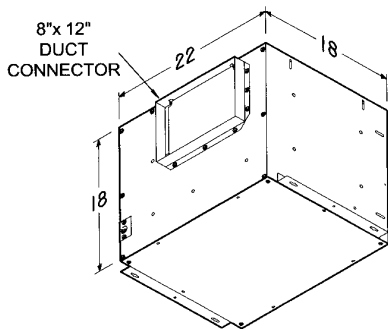

**FFC2000**

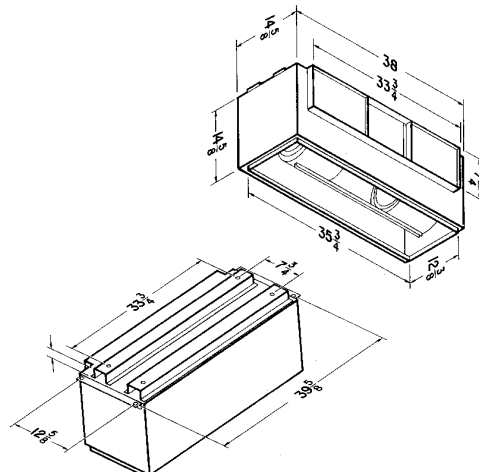

**FFC3500**

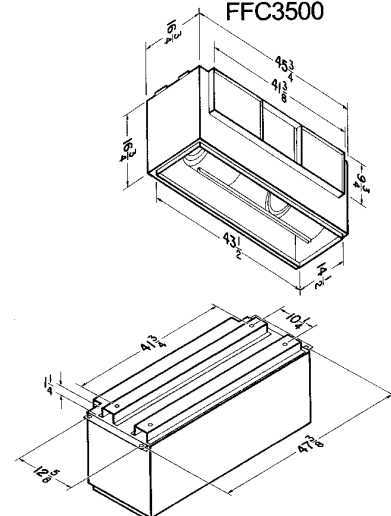

# ACCESSORIES

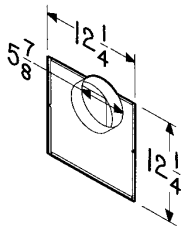

- 961L In-Line Adaptor Kit**
- Galvanized steel
  - Fits FF100 & FF150
  - For 6" round duct intake

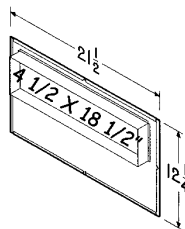

- 982L In-Line Adaptor Kit**
- Galvanized steel
  - Fits FF400, FF500 & FF700
  - 4 1/2 x 18 1/2" duct intake

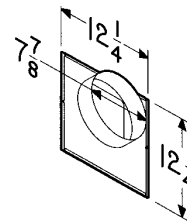

- 981L In-Line Adaptor Kit**
- Galvanized steel
  - Fits FF200, FF250 & FF300
  - For 8" round duct intake

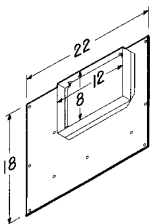

- 983 In-Line Adaptor Kit**
- Galvanized steel
  - Fits FF900 & FF1500
  - 8" x 12" round duct intake

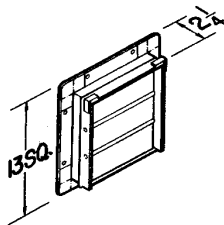

- Model 441 Wall Cap**
- Gravity dampers
  - Collar with birdscreen for attaching 10" round duct
  - Steel construction with aluminum louvers

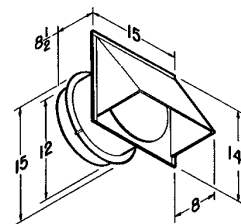

- Model 613 Wall Cap**
- High Capacity
  - Built-in backdraft damper & birdscreen
  - Aluminum natural finish
  - For 12" round duct

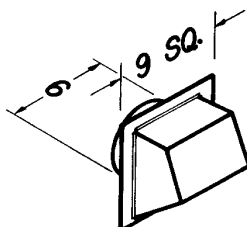

- Model 641 Wall Cap**
- Aluminum natural finish
  - Built-in backdraft damper & birdscreen
  - For 6" round duct

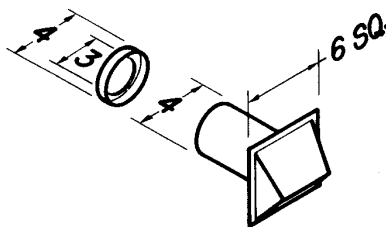

- Model 642 Wall Cap**
- Aluminum natural finish
  - Built-in backdraft damper & birdscreen
  - For 3" or 4" round duct (4" to 3" transition included)

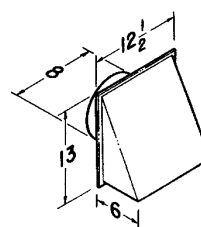

- Model 643 Wall Cap**
- Aluminum natural finish
  - Built-in backdraft damper
  - For 8" round duct

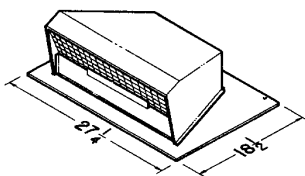

- Model 437 Roof Cap**
- High capacity design - up to 1200 CFM
  - Built-in birdscreen
  - Steel, black electrically - bonded epoxy finish

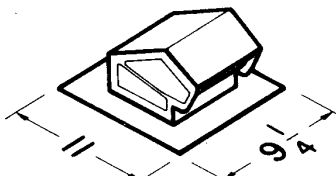

- Model 636 Roof Cap**
- Black electrically - bonded epoxy finish
  - Built-in backdraft damper & birdscreen
  - For 3" or 4" round duct

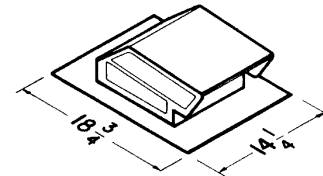

- Model 634 Roof Cap**
- Black electrically - bonded epoxy finish
  - Built-in backdraft damper & birdscreen
  - For 3 1/4" x 10" or up to 8" round duct

**Model 636AL - Aluminum**

**Model 644 - Aluminum**

# ACCESSORIES (cont.)

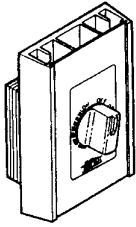

### Speed Control

- Adjust speed from 100 to 50%
- 5 amp & 10 amp - 120V
- 6 amp - 240V
- 6 amp - 277V

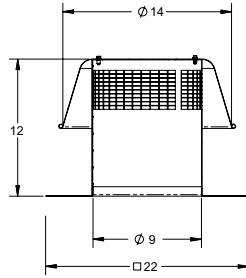

### Model RCXIISF08 Flat Roof Cap

- For flat roof installation
- Spun Aluminum - natural finish
- Built-in birdscreen
- For up to 8" round duct

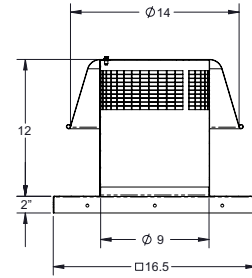

### Model RCXII08

#### Curb Mount Roof Cap

- For curb mount installation
- Use 14-3/4" x 14-3/4" x 8" high curb
- Spun Aluminum - natural finish
- Built-in birdscreen
- For up to 8" round duct

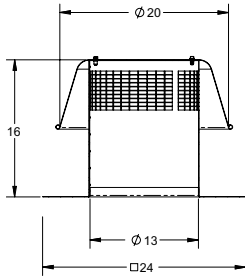

### Model RCXIISF12 Flat Roof Cap

- For flat roof installation
- Spun Aluminum - natural finish
- Built-in birdscreen
- For up to 12" round duct

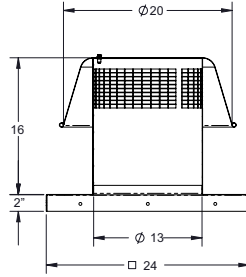

### Model RCXII12

#### Curb Mount Roof Cap

- For curb mount installation
- Use 22-1/4" x 22-1/4" x 8" high curb.
- Spun Aluminum - natural finish
- Built-in birdscreen
- For up to 12" round duct

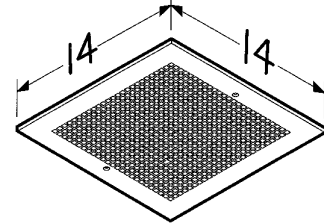

### Model MG 1 Metal Grille Kit

- White enamel painted steel
- Mounting screws included
- Fits FF100, FF150, FF200, FF250 & FF300

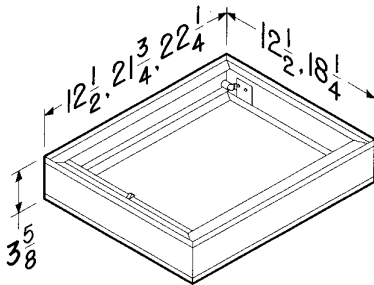

### Models RD1, RD2 & RD3 Radiation Dampers

- UL rated for use in 1, 2 or 3 hour rated floor-ceiling, roof-ceiling design
- Galvanized steel frame
- High temperature, non-asbestos, reinforced fiber thermal fabric
- 212°F fusible link
- Stainless steel negator-type closure spring
- RD1 (12 1/4" x 12 1/4") fits FF100 - FF300
- RD2 (21 1/2" x 18") fits FF400 - FF700
- RD3 (22" x 18") fits FF900 - FF1500

### Models 423 & T81212 Duct Transitions

- Galvanized steel
- Allows for quick transition to easy-to-obtain-and-install round ducting
- 423 ( 4 1/2" x 18" to 10 round) for use with FF400 thru FF700
- T81212 ( 8" x 12" to 12" round) for use with FF900 and FF1500

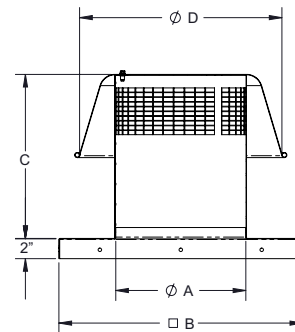
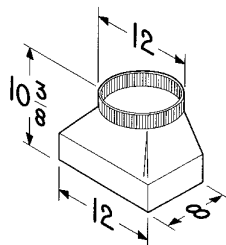
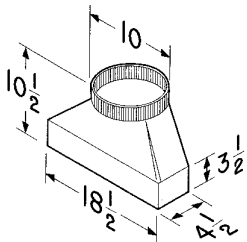

### Model RCXII - 18" and 20" units

Size	A	B	C	D
18	19	29.5	22	27
20	21	29.5	22	30

# OPTIONAL ACCESSORY COMPATIBILITY CHART

VARIABLE SPEED CONTROLS	CEILING MOUNT MODEL FF							IN-LINE/CABINET MODEL FFC						
	FF50 FF50E FF80	FF100 FF150	FF200 FF250 FF300	FF400 FF500	FF700	FF900	FF1500	FFC100 FFC150	FFC200 FFC250 FFC300	FFC400 FFC500 FFC700	FFC900	FFC1500	FFC2000	FFC3500
2727.1 (5 AMP 120V)	X	X	X	X			X	X						
2828.1 (10AMP 120V)		X	X	X	X	X	X	X	X	X	X	X	X	
80L in-unit speed control (3 amp 120 Volt) Ships separately for field mounting		X	X	X	X	X		X	X	X	X			
75V (240V)		X	X	X	X	X								X
277V (277V)		X	X	X	X	X	X							
<b>ROOF CAPS</b>														
437				X	X					X				
RCXII08, RCXIISF08	X	X	X					X	X					
RCXII12, RCXIISF12		X	X	X	X	X	X	X	X	X	X	X	X	
634M		X						X						
634,644		X	X					X	X					
636, 636AL	X													
RCXII18													X	
RCXII20														X
<b>WALL CAPS</b>														
441				X	X					X				
613							X	X			X	X		
641		X							X					
642	X													
643			X						X					
<b>IN-LINE ADAPTERS</b>														
961L		X												
981L			X											
982L				X	X									
983L						X	X							
<b>UL RADIATION DAMPERS</b>														
RD1		X	X											
RD2				X	X									
RD3						X	X							
<b>METAL Grille KIT</b>														
G102													X	
G103														X
MG1		X	X											
<b>DUCT TRANSITIONS</b>														
423				X	X					X				
T81212						X	X				X	X		
<b>DAMPER KITS</b>														
D100													X	
D101														X
<b>VIBRATION DAMPENING HANGERS (4)</b>														
V102	X	X	X	X	X	X	X	X	X	X	X			
V104		X	X	X	X	X	X	X	X	X	X	X	X	X

# FF CEILING VENTILATORS QUICK SELECTION GUIDE

**FF50**

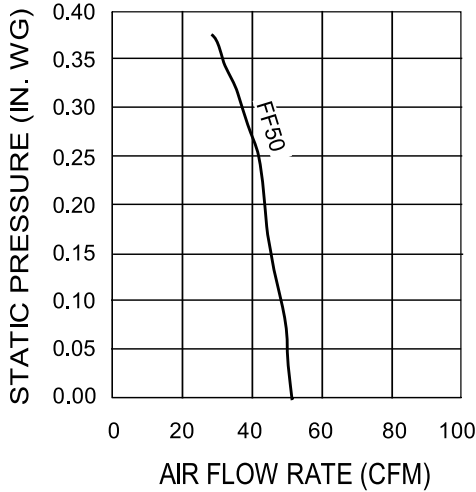

**FF80**

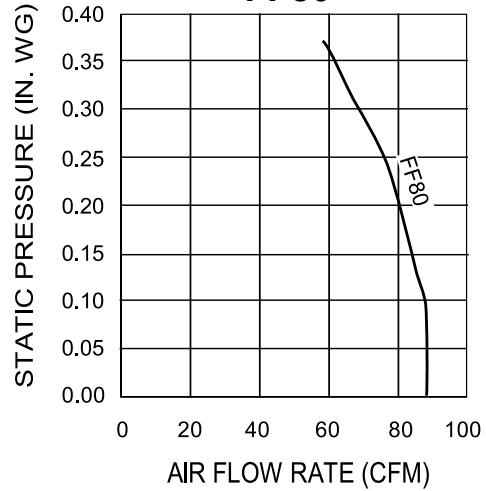

**FF100, FF150**

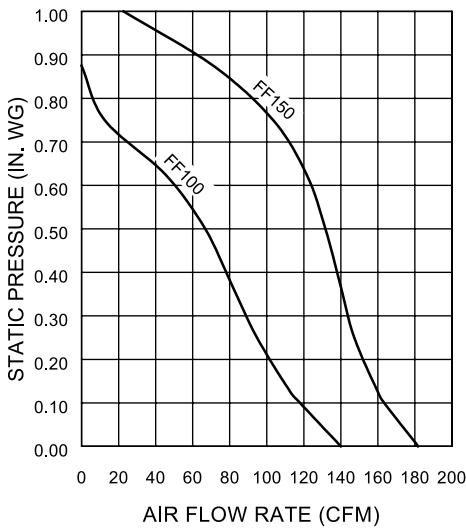

**FF200, FF250, FF300**

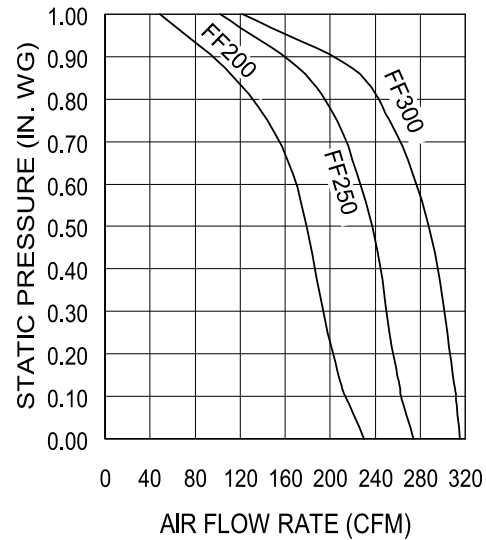

**FF400, FF500, FF700**

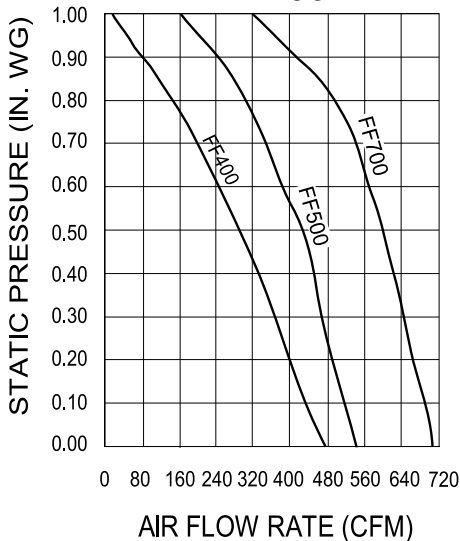

**FF900, FF1500**

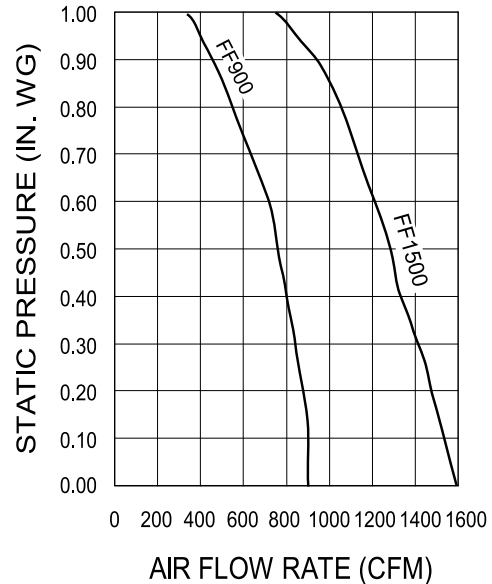

Models FF50, 80, 100, 150, 200, 250, 300, 400, 500, 700, 900, and 1500 Performance certified is for installation type B: Free inlet, Ducted outlet. Performance ratings include the effects of inlet grille and backdraft damper.

# FFC INLINE/CABINET VENTILATORS QUICK SELECTION GUIDE

**FFC100, FFC150**

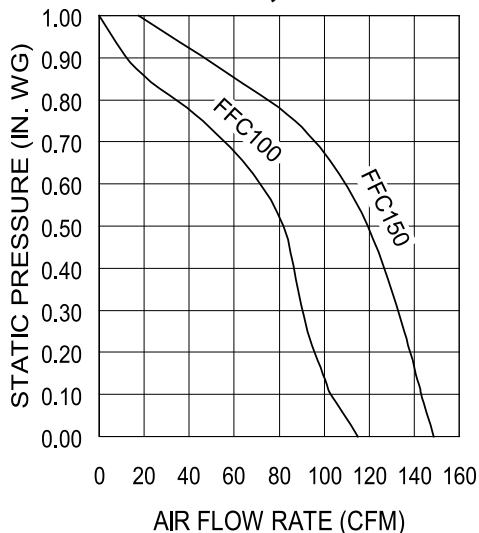

**FFC200, FFC250, FFC300**

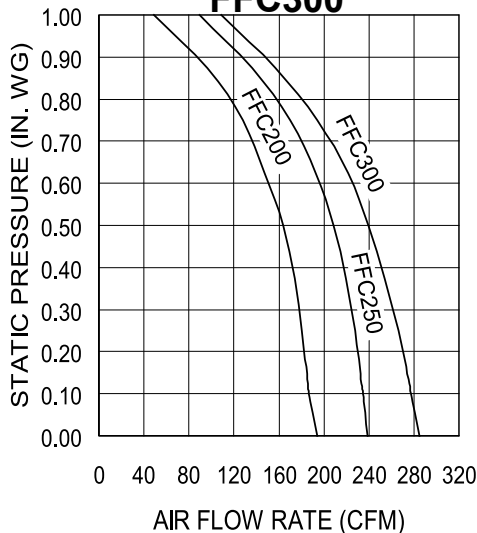

**FFC400, FFC500, FFC700**

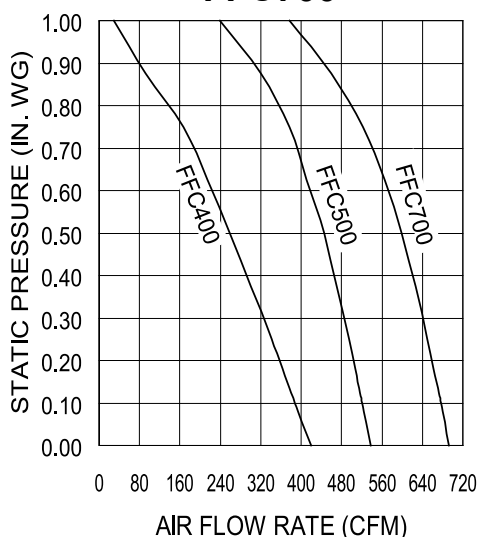

**FFC900, FFC1500**

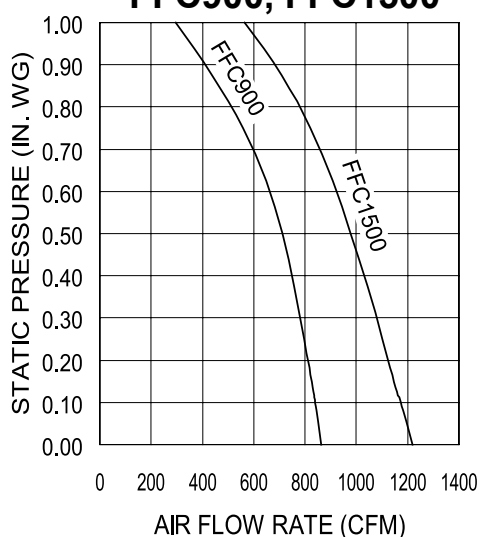

**FFC2000, FFC3500**

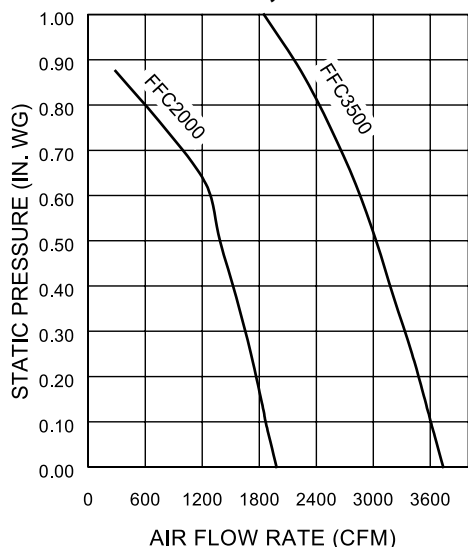

**FF & FFC QUICK SELECTION GUIDELINES**

1. Locate desired CFM on bottom horizontal axis of graph.
2. Locate system static pressure on left vertical axis of graph.
3. Determine intersection of CFM and static pressure.
4. Select fan curve to the right of this intersection.
5. Solid state speed control may be used for selections left of curve, up to 50% CFM reduction.

Models FFC100, 150, 200, 250, 300, 400, 500, 700, 900 and 1500 Performance certified is for installation type D: Ducted inlet, Ducted outlet. Performance ratings include the effects of backdraft damper, 18 feet of round inlet duct and, if needed, a rectangular to round duct transition.

Models FFC2000 and 3500 Performance certified is for installation type D: Ducted inlet, Ducted outlet. Performance ratings do not include the effects of appurtenances (accessories).