

Models UBB & UBX Cutaway Diagram

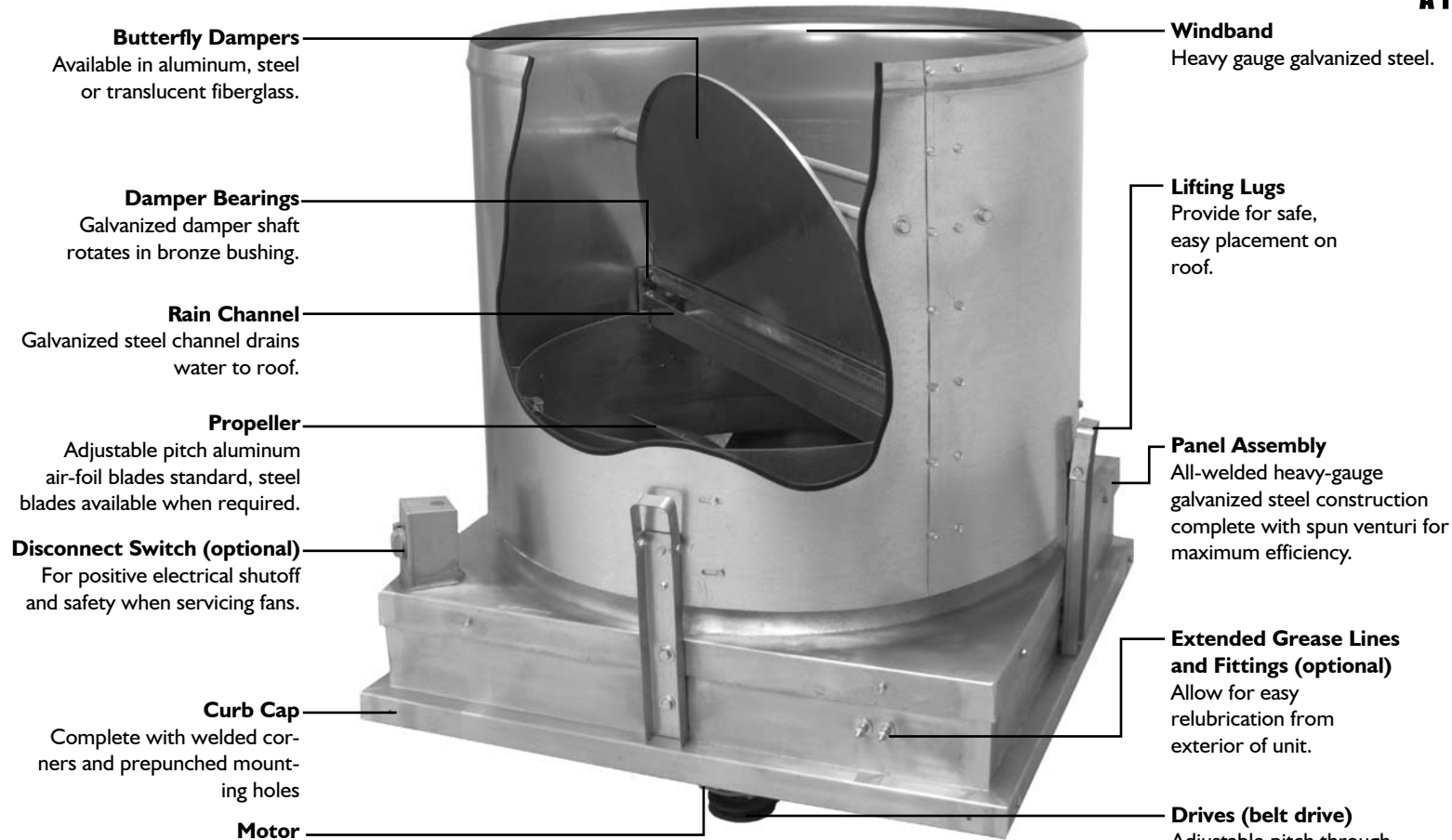

Butterfly Dampers
Available in aluminum, steel or translucent fiberglass.

Damper Bearings
Galvanized damper shaft rotates in bronze bushing.

Rain Channel
Galvanized steel channel drains water to roof.

Propeller
Adjustable pitch aluminum air-foil blades standard, steel blades available when required.

Disconnect Switch (optional)
For positive electrical shutoff and safety when servicing fans.

Curb Cap
Complete with welded corners and prepunched mounting holes

Motor
Open drip-proof standard, many options available.

cULus Standard 705 (Optional)
Listed Power Roof Ventilator assures electrical reliability.

Windband
Heavy gauge galvanized steel.

Lifting Lugs
Provide for safe, easy placement on roof.

Panel Assembly
All-welded heavy-gauge galvanized steel construction complete with spun venturi for maximum efficiency.

Extended Grease Lines and Fittings (optional)
Allow for easy relubrication from exterior of unit.

Drives (belt drive)
Adjustable pitch through 3 HP, all are sized for minimum 150% of drive HP.

AMCA Seal
Assures certified rating of air and sound performance

Factory Run & Tested
For quality assurance and dependable operation.

Slide Base (belt drive)
Tension rods for easy belt adjustment. (Not shown)

Bearings (belt drive)
Cast iron pillow blocks, double sealed and pre-lubricated, designed for 200,000 hour life. (Not shown)



Standard 705 (optional)
Excludes UBX