

MODEL UBSRD REMOTE DRIVE UPBLAST PROPELLER ROOF EXHAUSTER



6393 Powers Avenue
Jacksonville, Florida 32217-2298
P: 904.731.4711 / F: 904.737.8322
www.jencofan.com



FEATURES:

- Motors located outside the airstream under weather cover
- Die formed, epoxy coated, steel propeller blades
- Heavy-gauge G90 steel panel and damper doors
- One piece venturi for maximum efficiency and strength
- G90 galvanized steel windband
- Galvanized rain channel drain
- Drives sized for minimum 150% of drive HP
- Cast iron self-aligning pillow block bearings, sealed, pre-lubricated, and furnished with re-lube fittings
- Bearings have minimum 200,000 hour, L50 life

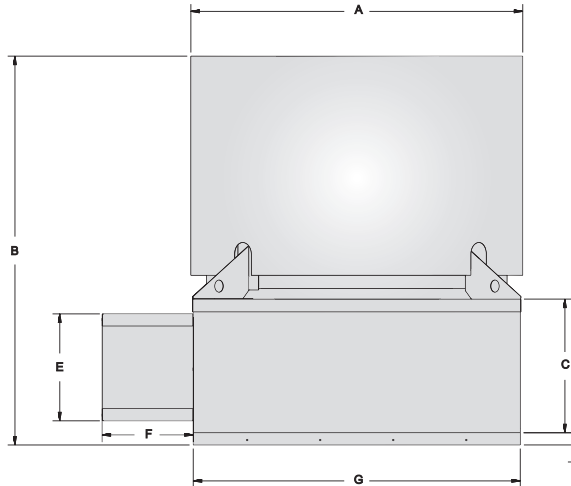

Model	A	B	C	D	E	F	G	H	I	Wt. (lbs)
24	30	49	22	2	17-1/2	15	29-1/2	28-1/2	25-1/2	310
30	36	52	22	2	17-1/2	15	35-1/2	34-1/2	31-1/2	340
36	42	58	22	2	17-1/2	15	41-1/2	40-1/2	37-1/2	430
42	48	61	22	2	17-1/2	15	47-1/2	46-1/2	43-1/2	490
48	54	64	22	2	17-1/2	15	53-1/2	52-1/2	49-1/2	640
54	60	67	22	2	17-1/2	15	59-1/2	58-1/2	55-1/2	840
60	66	70	22	2	17-1/2	15	65-1/2	64-1/2	61-1/2	1000

- A** - Outside Diameter Windband
- B** - Total Height of Unit
- C** - Housing Height
- D** - Curb Cap Depth
- E** - Motor Cover Height
- F** - Motor Cover Width
- G** - Inside Dimension of Square Curb Cap
- H** - OD of factory built prefab curb.
- I** - Recommended roof opening (inside dimension of factory built prefab curb.)

Model	Windband (galv)	Curb Cap (Galv)	Butterfly Damper		Housing (galv)	Drive Support Channel	Channel Support	Motor Bracket	Drive Shaft Size	Max Motor Frame Size
			Galv	Alum	Front/Back					
24	20	14	20	0.04	18	12	12	10	1	145T
30	20	14	20	0.04	18	12	12	10	1	184T
36	20	14	20	0.04	18	12	12	10	1	184T
42	20	14	20	0.04	18	12	12	10	1-7/16	215T
48	20	14	20	0.04	18	12	12	10	1-7/16	215T
54	20	14	20	0.04	18	12	12	10	1-7/16	215T
60	20	14	20	0.04	18	12	12	10	1-7/16	215T

FAN SPECIFICATIONS									MOTOR SPECIFICATIONS				
Line	Qty.	Model No.	Tag	CFM	SP	Fan RPM	BHP	Sones	HP	Volts	Phase	Hertz	Encl
1													
2													
3													
4													
5													

ACCESSORY ITEMS					ACCESSORY ITEMS				
1	2	3	4	5	1	2	3	4	5
<input type="checkbox"/>					<input type="checkbox"/>				
<input type="checkbox"/>					<input type="checkbox"/>				

Project: _____ Submitted: _____
 Customer: _____ Approved: _____
 Location: _____

MODEL UBSRD-HT REMOTE DRIVE UPBLAST PROPELLER ROOF EXHAUSTER for HEAT AND SMOKE REMOVAL



6393 Powers Avenue
Jacksonville, Florida 32217-2298
P: 904.731.4711 / F: 904.737.8322
www.jencofan.com

Soler&Palau
Ventilation Group



FEATURES:

- Successfully tested by independent laboratory for: 1000° F for 15 minutes and 500° F for 4 hours
- Motors located outside the airstream under weather cover
- Heavy-gauge insulated belt tube and cover
- Die formed, epoxy coated, steel propeller blades
- Heavy-gauge G90 steel panel and damper doors
- One piece venturi for maximum efficiency and strength
- G90 galvanized steel windband
- Galvanized rain channel drain
- Dual groove drives sized for minimum 150% of drive HP
- Cast iron self-aligning pillow block bearings, sealed, pre-lubricated, and furnished with re-lube fittings
- Bearings have minimum 200,000 hour, L50 life

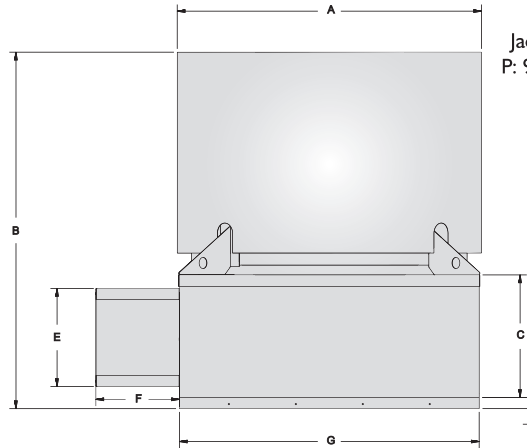

Model	A	B	C	D	E	F	G	H	I	Wt. (lbs)
24	30	49	22	2	17-1/2	15	29-1/2	28-1/2	25-1/2	310
30	36	52	22	2	17-1/2	15	35-1/2	34-1/2	31-1/2	340
36	42	58	22	2	17-1/2	15	41-1/2	40-1/2	37-1/2	430
42	48	61	22	2	17-1/2	15	47-1/2	46-1/2	43-1/2	490
48	54	64	22	2	17-1/2	15	53-1/2	52-1/2	49-1/2	640
54	60	67	22	2	17-1/2	15	59-1/2	58-1/2	55-1/2	840
60	66	70	22	2	17-1/2	15	65-1/2	64-1/2	61-1/2	1000

- A** - Outside Diameter Windband
- B** - Total Height of Unit
- C** - Housing Height
- D** - Curb Cap Depth
- E** - Motor Cover Height
- F** - Motor Cover Width
- G** - Inside Dimension of Square Curb Cap
- H** - OD of factory built prefab curb.
- I** - Recommended roof opening (inside dimension of factory built prefab curb.)

Model	Windband (galv)	Curb Cap (Galv)	Butterfly Damper		Housing (galv) Front/Back	Drive Support Channel	Channel Support	Motor Bracket	Drive Shaft Size	Max Motor Frame Size
			Galv	Alum						
24	20	14	20	0.04	18	12	12	10	1	145T
30	20	14	20	0.04	18	12	12	10	1	184T
36	20	14	20	0.04	18	12	12	10	1	184T
42	20	14	20	0.04	18	12	12	10	1-7/16	215T
48	20	14	20	0.04	18	12	12	10	1-7/16	215T
54	20	14	20	0.04	18	12	12	10	1-7/16	215T
60	20	14	20	0.04	18	12	12	10	1-7/16	215T

FAN SPECIFICATIONS									MOTOR SPECIFICATIONS				
Line	Qty.	Model No.	Tag	CFM	SP	Fan RPM	BHP	Sones	HP	Volts	Phase	Hertz	Encl
1													
2													
3													
4													
5													

ACCESSORY ITEMS					1	2	3	4	5	ACCESSORY ITEMS					1	2	3	4	5
<input type="checkbox"/>										<input type="checkbox"/>									
<input type="checkbox"/>										<input type="checkbox"/>									

Project: _____ Submitted: _____
 Customer: _____ Approved: _____
 Location: _____

MODEL UBSRD-HTI REMOTE DRIVE UPBLAST PROPELLER ROOF EXHAUSTER for HEAT AND SMOKE REMOVAL



6393 Powers Avenue
Jacksonville, Florida 32217-2298
P: 904.731.4711 / F: 904.737.8322
www.jencofan.com

Soler&Palau
Ventilation Group



FEATURES:

- Successfully tested by independent laboratory for: 1000° F for 15 minutes and 500° F for 4 hours
- 165° F fusible link in damper mechanism
- Motors located outside the airstream under weather cover
- Heavy-gauge insulated belt tube and cover
- Die formed, epoxy coated, steel propeller blades
- Heavy-gauge G90 steel panel and damper covers
- One piece venturi for maximum efficiency and strength
- G90 galvanized steel windband
- Galvanized rain channel drain
- Dual groove drives sized for minimum 150% of drive HP
- Cast iron self-aligning pillow block bearings, sealed, pre-lubricated, and furnished with re-lube fittings
- Bearings have minimum 200,000 hour, L50 life

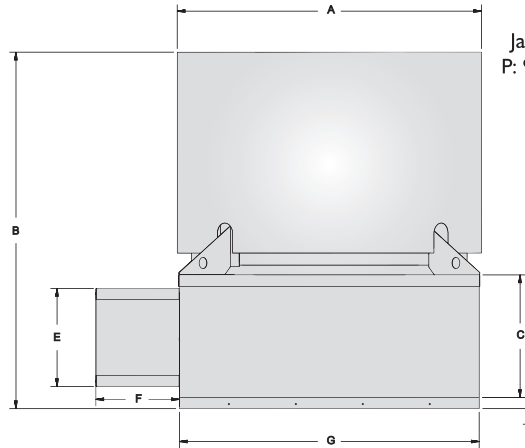

Model	A	B	C	D	E	F	G	H	I	Wt. (lbs)
24	30	49	22	2	17-1/2	15	29-1/2	28-1/2	25-1/2	310
30	36	52	22	2	17-1/2	15	35-1/2	34-1/2	31-1/2	340
36	42	58	22	2	17-1/2	15	41-1/2	40-1/2	37-1/2	430
42	48	61	22	2	17-1/2	15	47-1/2	46-1/2	43-1/2	490
48	54	64	22	2	17-1/2	15	53-1/2	52-1/2	49-1/2	640
54	60	67	22	2	17-1/2	15	59-1/2	58-1/2	55-1/2	840
60	66	70	22	2	17-1/2	15	65-1/2	64-1/2	61-1/2	1000

- A** - Outside Diameter Windband
- B** - Total Height of Unit
- C** - Housing Height
- D** - Curb Cap Depth
- E** - Motor Cover Height
- F** - Motor Cover Width
- G** - Inside Dimension of Square Curb Cap
- H** - OD of factory built prefab curb.
- I** - Recommended roof opening (inside dimension of factory built prefab curb.)

Model	Windband (galv)	Curb Cap (Galv)	Butterfly Damper		Housing (galv) Front/Back	Drive Support Channel	Channel Support	Motor Bracket	Drive Shaft Size	Max Motor Frame Size
			Galv	Alum						
24	20	14	20	0.04	18	12	12	10	1	145T
30	20	14	20	0.04	18	12	12	10	1	184T
36	20	14	20	0.04	18	12	12	10	1	184T
42	20	14	20	0.04	18	12	12	10	1-7/16	215T
48	20	14	20	0.04	18	12	12	10	1-7/16	215T
54	20	14	20	0.04	18	12	12	10	1-7/16	215T
60	20	14	20	0.04	18	12	12	10	1-7/16	215T

FAN SPECIFICATIONS									MOTOR SPECIFICATIONS				
Line	Qty.	Model No.	Tag	CFM	SP	Fan RPM	BHP	Sones	HP	Volts	Phase	Hertz	Encl
1													
2													
3													
4													
5													

ACCESSORY ITEMS					ACCESSORY ITEMS				
1	2	3	4	5	1	2	3	4	5
<input type="checkbox"/>					<input type="checkbox"/>				
<input type="checkbox"/>					<input type="checkbox"/>				

Project: _____ Submitted: _____
 Customer: _____ Approved: _____
 Location: _____