

# CWD - DIRECT DRIVE CENTRIFUGAL SIDEWALL MOUNTED EXHAUSTER

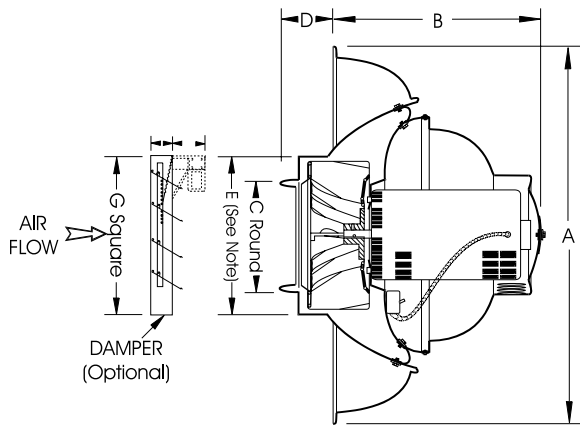

## FEATURE

- Heavy-gauge, corrosion free, spun aluminum housing and all stainless steel fastenings.
- Permanently lubricated motor, mounted in compartment sealed from exhaust airstream.
- Exclusive steel U-spring suspension for permanent maximum vibration isolation.
- Nonoverloading all aluminum wheel dynamically and statically balanced.
- Internal, watertight, aluminum wiring post provided for electrical conduit.
- Aluminum birdscreen

**NOTE:** For round duct connection to unit without damper, cut a circular hole in the wall to dimension E.

**NOTE:** Disconnect switch ships loose for field installation and wiring.



JencoFan, Div. of Soler & Palau Ventilation Group certifies that the Models CWD shown herein are licensed to bear the AMCA Seal. The ratings shown are based on test and procedures performed in accordance with AMCA Publication 211 and AMCA Publication 311 and comply with the requirement of the AMCA Certified Ratings Program.



SUBMITTAL DRAWING

MODEL NO.	DIMENSIONS (IN)						AVG. SHIP WT. (LBS)
	A	B	C	D	E	G	
070A	15	8	5 15/16	1 1/2	8	11	15
080A	20	9	9 15/16	2	12	11	25
090A - 101A	26	13 1/2	11 15/16	3	15	14	37
110A - 121A	30	15 1/2	13 15/16	3	17 1/2	14	80
141A	36	16 1/2	17 15/16	4	22	18	84

FAN SPECIFICATIONS									MOTOR SPECIFICATIONS				
Line	Qty.	Model No.	Tag	CFM	SP	Fan RPM	BHP	Sones	HP	Volts	Phase	Hertz	Encl
1													
2													
3													
4													
5													

ACCESSORY ITEMS					ACCESSORY ITEMS						
	1	2	3	4	5		1	2	3	4	5
<input type="checkbox"/>						<input type="checkbox"/>					
<input type="checkbox"/>						<input type="checkbox"/>					
<input type="checkbox"/>						<input type="checkbox"/>					
<input type="checkbox"/>						<input type="checkbox"/>					
<input type="checkbox"/>						<input type="checkbox"/>					

Project: _____	Submitted: _____
Customer: _____	Approved: _____
Location: _____	