

TXB-UL762 LISTED RESTAURANT ROOF EXHAUSTER CENTRIFUGAL UPBLAST BELT DRIVE

FAN FEATURES

- AMCA Air and Sound Licensed
- UL 705 listed
- UL 762 listed for Grease Removal
- Rainproof electrical box with wiring chase
- Heavy-gauge aluminum construction
- Nonoverloading aluminum backward inclined wheel
- Drives sized for a minimum of 150% of motor horsepower
- 1 year fan and motor warranty
- Heavy-duty 200,000 hour rated pillow block bearings
- Single piece deep spun inlet with welded corners

SIZE	METAL GAUGES					
	WIND BAND	MOTOR COVER	L	BASE		CURB CAP FLANGE
				STD/UL	RHUL	
8/10	.050	.050	.063	.063	16GA	.050
12/15/16	.050	.050	.063	.063	16GA	.050
18/20	.050	.050	.063	.080	16GA	.063
24	.050	.050	.080	.080	16GA	.080

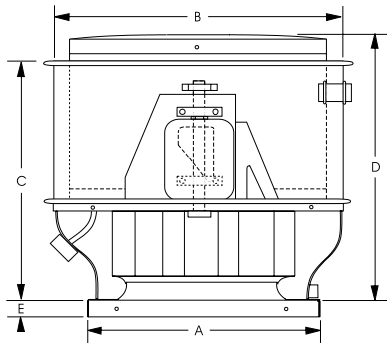

JencoFan, Div. of Soler & Palau Ventilation Group certifies that the Models TXB shown herein are licensed to bear the AMCA Seal. The ratings shown are based on test and procedures performed in accordance with AMCA Publication 211 and AMCA Publication 311 and comply with the requirement of the AMCA Certified Ratings Program.



SIZE	DIMENSIONS (IN.)							AVG. SHIP WT. (LBS)
	A	B	C	D	E	F	G	
8	16 1/2	24	24	27	1 3/4	11 3/4	14 3/4	69
10	16 1/2	27	26	29	1 3/4	11 3/4	14 3/4	69
12/15/16	24	31 1/2	26	28 3/4	2 1/2	19 1/4	22 1/4	93
18/20	29 1/2	37 3/4	28 1/2	31 3/4	2 1/2	24 3/4	27 3/4	120
24	35 1/2	47 1/4	31 1/2	41	2 1/2	30 3/4	33 3/4	245

- A - Inside dimension of square curb cap.
- B - Outside diameter of unit.
- C - Height of exhaust opening above curb cap.
- D - Height of unit above top of curb.
- E - Depth of curb mounting flange.
- F - Recommended roof opening.
(Inside dimension of factory built prefab curb).
- G - Outside dimension of factory built prefab curb.

FAN SPECIFICATIONS										MOTOR SPECIFICATIONS				
Line	Qty.	Model No.	Tag	CFM	SP	Fan RPM	BHP	Sones	HP	Volts	Phase	Hertz	Encl	
1														
2														
3														
4														
5														

ACCESSORY ITEMS					ACCESSORY ITEMS						
	1	2	3	4	5		1	2	3	4	5
<input type="checkbox"/>						<input type="checkbox"/>					
<input type="checkbox"/>						<input type="checkbox"/>					
<input type="checkbox"/>						<input type="checkbox"/>					
<input type="checkbox"/>						<input type="checkbox"/>					
<input type="checkbox"/>						<input type="checkbox"/>					