

# TXD - DIRECT DRIVE CENTRIFUGAL UPBLAST ROOF EXHAUSTER

## STANDARD CONSTRUCTION FEATURES

- Aluminum housing with stainless steel exterior fasteners.
- UL 705 listed.
- Aluminum backward inclined wheel.
- Prepunched aluminum curb cap with welded corners.
- Single piece aluminum birdscreen & windband.
- Neoprene vibration mounts.
- Conduit wiring chase.
- Factory disconnect switch or plug type. (except XP & 2 speed).

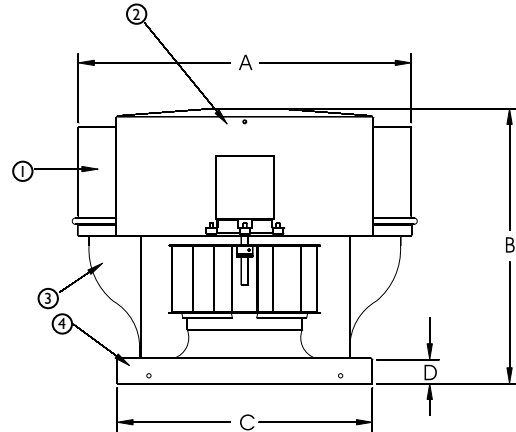

SIZE	DIMENSIONS (IN.)			
	A	B	C	D
6 / 8	24	22	16 1/2	2
10	27 1/4	22	16 1/2	2
12	31 1/2	23	24	2
14 / 15	31 1/2	23	24	2



JencoFan, Div. of Soler & Palau Ventilation Group certifies that the Models TXD shown herein are licensed to bear the AMCA Seal. The ratings shown are based on test and procedures performed in accordance with AMCA Publication 211 and AMCA Publication 311 and comply with the requirement of the AMCA Certified Ratings Program.



- A - Outside diameter of unit.
- B - Height of unit.
- C - Inside dimension of square curb cap.
- D - Motor compartment diameter.

SIZE	DIMENSIONS (IN.)			ALUMINUM METAL GAUGES				FAN WT. (LBS)	AVG. SHIP WT. (LBS)
	DAMPER OD	ROOF OPENING	CURB OD	WIND BAND ①	MOTOR COVER ②	SHROUD ③	BASE ④		
6 / 8	11	12	15	.050	.080	.063	.050	37	70
10	11	12	15	.050	.050	.063	.063	40	73
12	18	19 1/4	22 1/4	.050	.050	.063	.063	70	115
14 / 15	18	19 1/4	22 1/4	.050	.050	.063	.063	75	120

FAN SPECIFICATIONS									MOTOR SPECIFICATIONS				
Line	Qty.	Model No.	Tag	CFM	SP	Fan RPM	BHP	Sones	HP	Volts	Phase	Hertz	Encl
1													
2													
3													
4													
5													

ACCESSORY ITEMS	1	2	3	4	5	ACCESSORY ITEMS	1	2	3	4	5
<input type="checkbox"/>						<input type="checkbox"/>					
<input type="checkbox"/>						<input type="checkbox"/>					
<input type="checkbox"/>						<input type="checkbox"/>					
<input type="checkbox"/>						<input type="checkbox"/>					
<input type="checkbox"/>						<input type="checkbox"/>					

SUBMITTAL DRAWING