

MODELS ARE & ARS DIRECT DRIVE AXIAL ROOF EXHAUST & SUPPLY FANS



6393 Powers Avenue
Jacksonville, Florida 32217-2298
P: 904.731.4711 / F: 904.737.8322
www.jencofan.com



STANDARD FEATURES

- Permanently lubricated motor is mounted outside airstream.
- Exclusive U-spring suspension compensates for both radial and lateral movement, providing 44% better vibration isolation than rubber isolators.
- External, watertight, aluminum wiring post supplied for electrical conduit.
- Heavy-gauge spun aluminum housing gives unit strength without weight; eliminates rust.
- Pressure type axial fan with conic inlet construction assures quiet and efficient performance.
- High point of discharge with low contour.
- Disconnect switch (except explosion proof).

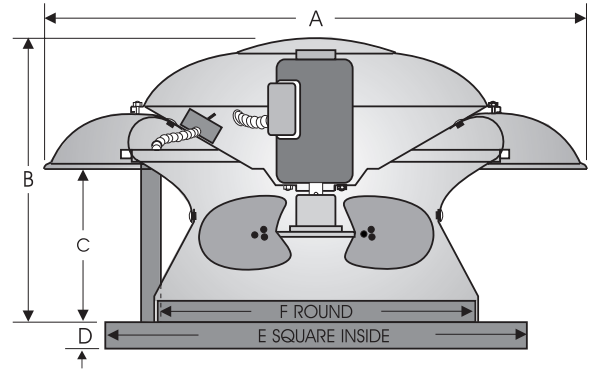

MODEL NO.	DIMENSIONS (IN)							Recommended Curb O.D.	AVG. SHIP WT. (LBS)
	A	B	C	D	E	Orifice F	Damper O.D. G		
100A	21	13	7	2	20	13-3/4	14	18-1/2	25
120A	28	16	8	3	24	15-3/4	18	22-1/2	42
121A	28	16	8	3	24	15-3/4	18	22-1/2	42
160A	32	18	8-1/2	3	28	19-3/4	22	26-1/2	55
161A	32	18	8-1/2	3	28	19-3/4	22	26-1/2	55
201A	36	20	9-3/4	3	32	23-3/4	26	30-1/2	75

FAN SPECIFICATIONS									MOTOR SPECIFICATIONS				
Line	Qty.	Model No.	Tag	CFM	SP	Fan RPM	BHP	Sones	HP	Volts	Phase	Hertz	Encl
1													
2													
3													
4													
5													

ACCESSORY ITEMS	1	2	3	4	5	ACCESSORY ITEMS	1	2	3	4	5
<input type="checkbox"/>						<input type="checkbox"/>					
<input type="checkbox"/>						<input type="checkbox"/>					
<input type="checkbox"/>						<input type="checkbox"/>					
<input type="checkbox"/>						<input type="checkbox"/>					
<input type="checkbox"/>						<input type="checkbox"/>					

Project: _____ Submitted: _____
 Customer: _____ Approved: _____
 Location: _____