

BACKDRAFT DAMPERS FOR ROOF MOUNTED SUPPLY FANS

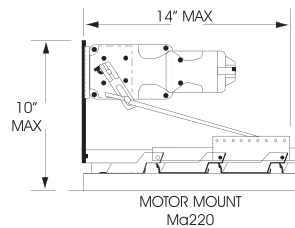

6393 Powers Avenue
Jacksonville, Florida 32217-2298
P: 904.731.4711 / F: 904.737.8322
www.jencofan.com

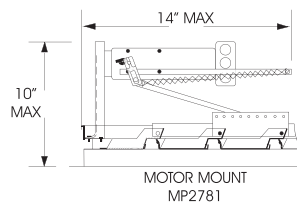

NOTE

Counter balance weight kits are required on all supply dampers (gravity or motor operated).

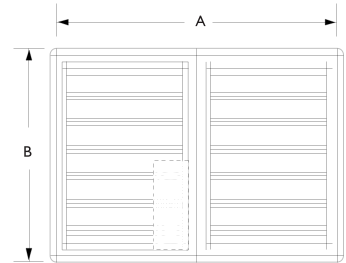
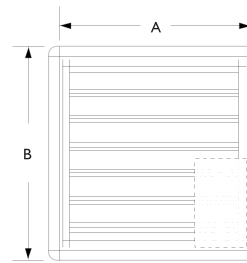
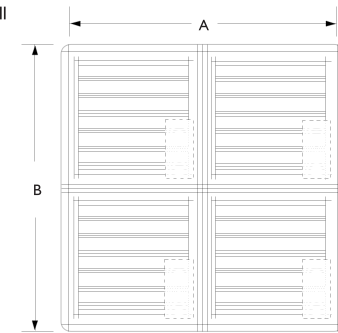
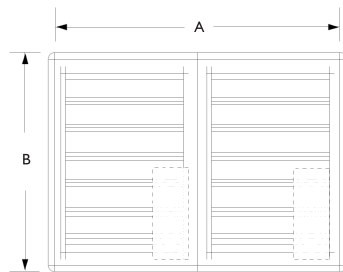

PLAN VIEW (TOP)

STANDARD SPECIFICATIONS:

Maximum Face Velocity: 3000 fpm.
Temperature limits: -40°F to 200°F (-40°C to 94°C)
Minimum Size: 8 x 8
Size: Single section: 42 x 64 Max W/H
Multiple section assembly - Unlimited size.

Frame: 20 gauge galvanized steel.

Blades: .025 thick aluminum.

HD 28 gauge galvanized steel.

Seals: Extruded vinyl mechanically locked into blades.

Axles: Stainless Steel.

Linkage: Stainless steel pins, galvanized steel tie bar.

Finish: Mill.

NOTES:

- (1) Do not mount fan less than 12 inches from the shutter.
- (2) Motors available in 24V, 120V, 240V & 440V.
- (3) Dampers shipped in individual cartons.
- (4) Motors and spring kits ship separately.
- (5) Center-pivoted dampers must be used on reversible fans.
- (6) Multiple section assemblies may require bracing to support the weight of the assembly and to hold against system pressure. **BRACING SUPPLIED BY OTHERS.**
- (7) Multiple section dampers are factory joined (except 72" and larger).

CAUTION: Motor kits are not suitable for use in explosive or flammable areas or airflows.

FAN SIZE	CENTRIFUGAL ROOF FANS						PROP ROOF FANS				MOTOR TYPE		PANELS (DETAIL)
	LSF, CSF & KSF		SRT		RCXII		HRSB, HRSBF, HRSDF		ARS A Sq	TYPE	QTY		
	A Sq SIZE	B Sq OD FLANGE	A Sq SIZE	B Sq FLANGE	A Sq SIZE	B Sq OD FLANGE	A Sq SIZE	B Sq OD FLANGE					
6 or 8	-	-	-	-	8	10-1/2	-	-	-	MP2781	1	1	
9	16	18-1/2	-	-	-	-	-	-	-	MP2781	1	1	
10	20	22-1/2	8	10-1/2	8	10-1/2	-	-	14	MP2781	1	1	
12	20	22-1/2	-	-	15	17-1/2	-	-	18	MP2781	1	1	
15	24	26-1/2	-	-	15	17-1/2	-	-	-	MP2781	1	1	
16	-	-	-	-	-	-	-	-	22	MP2781	1	1	
18	27	29-1/2	-	-	21	23-1/2	-	-	-	MP2781	1	1	
20	42	44-1/2	-	-	21	23-1/2	-	-	26	MP2781	1	1	
24/26	-	-	-	-	27	29-1/2	26	28-1/2	-	MP2781	1	1	
30/33	-	-	-	-	34	36-1/2	32	34-1/2	-	MP2781	1	1	
36	-	-	-	-	34	36-1/2	38	40-1/2	-	MP2781	1	1	
42	-	-	-	-	-	-	44	46-1/2	-	MA220	1	2	
48	-	-	-	-	-	-	50	52-1/2	-	MA220	1	2	
54	-	-	-	-	-	-	56	58-1/2	-	MA220	1	2	
60	-	-	-	-	-	-	62	65-1/2	-	MA220	1	2	
72	-	-	-	-	-	-	76	78-1/2	-	MP2781	4	4	

Heavy Duty Dampers required on all units with 7 1/2HP motors and above.

ACCESSORY ITEMS	1	2	3	4	5	ACCESSORY ITEMS	1	2	3	4	5
<input type="checkbox"/>						<input type="checkbox"/>					
<input type="checkbox"/>						<input type="checkbox"/>					
<input type="checkbox"/>						<input type="checkbox"/>					
<input type="checkbox"/>						<input type="checkbox"/>					
<input type="checkbox"/>						<input type="checkbox"/>					

Project: _____ Submitted: _____
 Customer: _____ Approved: _____
 Location: _____

BACKDRAFT DAMPER FOR ROOF MOUNTED AND INLINE CENTRIFUGAL/PROPELLER EXHAUST FANS



6393 Powers Avenue
Jacksonville, Florida 32217-2298
P: 904.731.4711 / F: 904.737.8322
www.jencofan.com

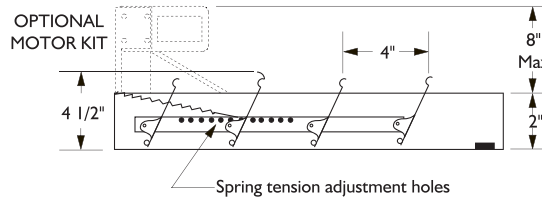
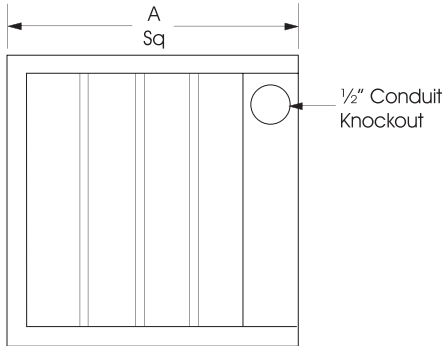

↑
AIR FLOW

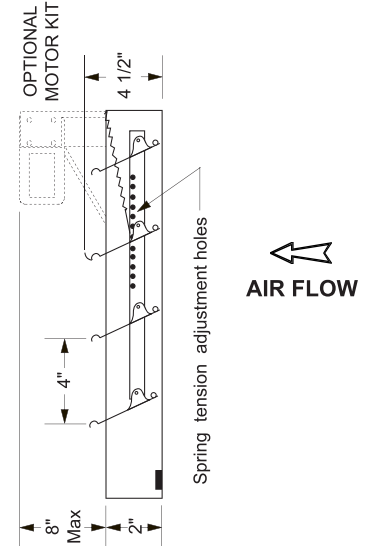

←
AIR FLOW

CAUTION: Motor kits are not suitable for use in explosive or flammable areas or airflows.

For low velocity (CFM) field adjustment of spring tension may be required to ensure that damper blades open completely.

FAN SIZE	CENTRIFUGAL ROOF FANS	INLINE FANS		PROPELLER
	DB, RED, TXB, LPD, TXD	SQB	SQD	ARE
	"A" SQUARE	"A" SQUARE	"A" SQUARE	"A" SQUARE
6	11	-	9	-
7	-	12	-	-
8	11	12	12	-
9	11	-	-	-
10	11	14	14	14
11/12	18	18	16	18
14	18	-	-	-
15	18	22	20	-
16	18	-	-	22
18	24	24	-	-
20	24	28	-	26
24	30	35	-	-
30	36	40	-	-
36	36	48	-	-
42	48	54	-	-
48	48	-	-	-

STANDARD SPECIFICATIONS:

Maximum Face Velocity: 1000 fpm.
Dimensions: See sizing chart
"A" Dimension is square damper size.
Frame: 19 Ga galvanized steel.
Blades: 26 gauge aluminum.
Blade pivots: Stainless steel rivet at all pivot points.
Seals: Felt between adjacent blades.
Counter Balance: Adjustable spring tension.
Finish: Mill.
Max Temp: Damper 250° F
Motor 130° F

CAUTION: Motor kits are not suitable for use in explosive or flammable areas or airflows.

NOTES:

- (1) Units are undersized 1/4" to fit in square ducts.
- (2) Do not mount fan less than 1/3 diameter of the fan from the damper.
- (3) Dampers shipped in individual cartons.
- (4) Motor kits ship loose for field installation.

ACCESSORY ITEMS	1	2	3	4	5	ACCESSORY ITEMS	1	2	3	4	5
<input type="checkbox"/>						<input type="checkbox"/>					
<input type="checkbox"/>						<input type="checkbox"/>					
<input type="checkbox"/>						<input type="checkbox"/>					
<input type="checkbox"/>						<input type="checkbox"/>					
<input type="checkbox"/>						<input type="checkbox"/>					

Project: _____ Submitted: _____
Customer: _____ Approved: _____
Location: _____

TYPE SF SELF-FLASHING CURB



6393 Powers Avenue
Jacksonville, Florida 32217-2298
P: 904.731.4711 / F: 904.737.8322
www.jencofan.com



STANDARD FEATURES

- Constructed of 18 ga. galv. steel with continuous welded seams and integral base plate for water tightness and extra strength.
- Wide base flashing to insure adequate bond to roofing surface for water tight seal to roof.
- Lined with 1-1/2" fiberglass fire proof sound attenuating thermal insulation.
- Top of curb covered with 1/4" polystyrene gasket for weather seal and to reduce metal to metal conducted noise.

PROJECT	
LOCATION	
ARCHITECT	
ENGINEER	
CONTRACTOR	
SUBMITTED BY	
DATE	P.O. NO.

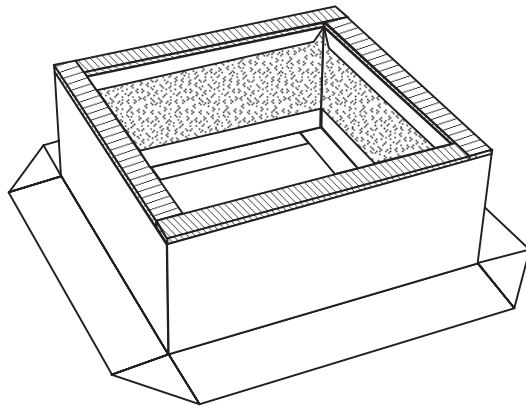
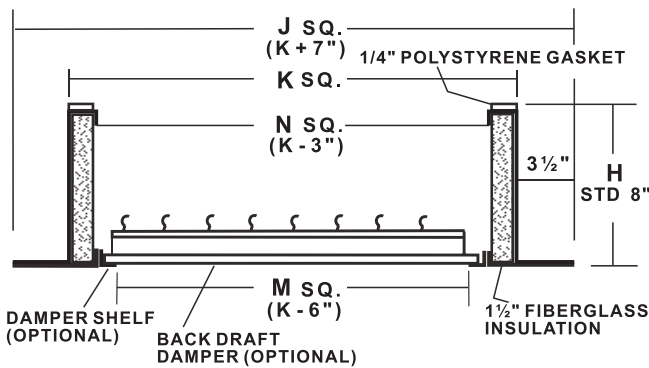

OPTIONS

- Constructed of .063" aluminum.
- Interior metal liner.
- Standard heights of 12, 14, 16, 18, 20, 24", or any special height.
- Damper shelf - standard or custom size opening.
- Wide flange (6" or 8" wide).
- Backdraft damper.
- Protective or decorative coatings.
- Heavy-gauge construction.

SPECIFICATIONS AND DIMENSIONS

REFERENCE	QUANTITY	GALV. OR ALUM.	K	N	M	H	OPTIONS

**CURB CAP ADAPTOR
SPUN PRODUCTS ONLY
(+ or - 4 inches)
Square ONLY - NO Rectangles**



6393 Powers Avenue
Jacksonville, Florida 32217-2298
P: 904.731.4711 / F: 904.737.8322
www.jencofan.com

Soler&Palau
Ventilation Group

STANDARD FEATURES

- Heavy-gauge aluminum construction with continuous welded seams for water tightness and extra strength.

PROJECT	
LOCATION	
ARCHITECT	
ENGINEER	
CONTRACTOR	
SUBMITTED BY	
DATE	P.O. NO.

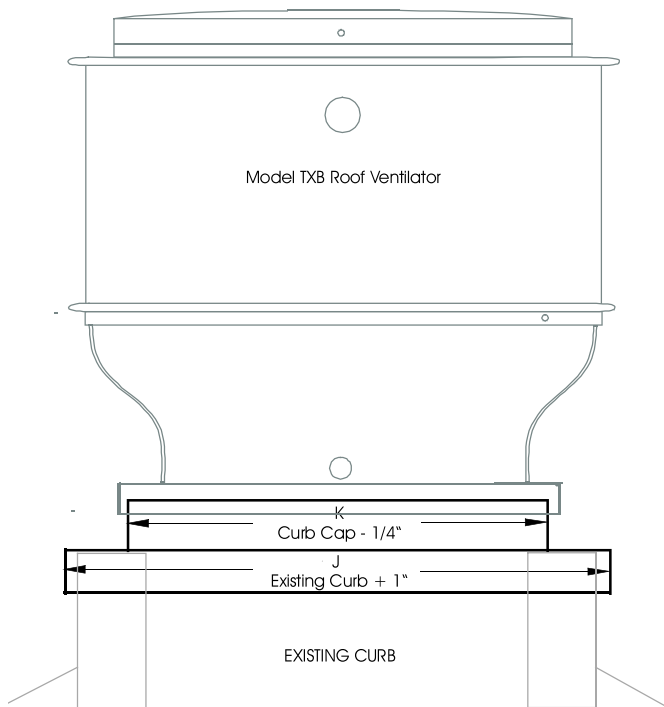

K - MEASUREMENT

1/4" LESS THAN FAN BASE

J - MEASUREMENT

1" LARGER THAN EXISTING CURB O.D.

SPECIFICATIONS AND DIMENSIONS				
REFERENCE	QUANTITY	K	J	OPTIONS

CURB HINGE ACCESSORY



6393 Powers Avenue
 Jacksonville, Florida 32217-2298
 P: 904.731.4711 / F: 904.737.8322
 www.jencofan.com
 Soler&Palau Ventilation Group

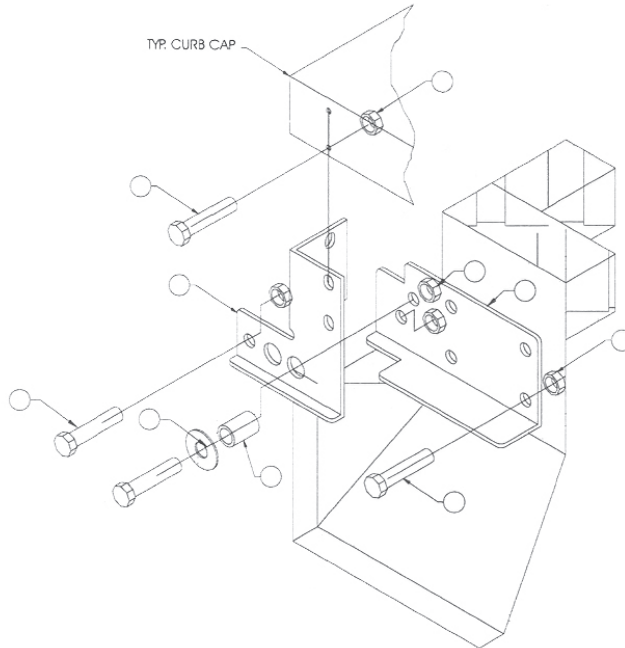

ITEM #	PART #	DESCRIPTION	QTY	ITEM #	PART #	DESCRIPTION	QTY
1	634012	3/8" Flat Washer	2	6	90005802	Hinge Bracket Left Half	1
2	634025	3/8-16 Loknut	2	7	90005101	Curb Hinge Bracket Right	1
3	603656	3/8 x 1-1/4" Long Spacer	2	8	634002	5/16-18 x 3/4 Hex Bolt	16
4	634138	3/8-16 x 2" Long Bolt	4	9	634027	5/16-18 Flange Nut	16
5	90005702	Hinge Bracket Right Half	1	10	90005201	Curb Hinge Bracket Left*	1
				11	634028	1 3/8-16 Flange Nut	2

*Items on opposite side, not shown

Note: Curb cap needs to be 1/2" minimum larger than the roof curb or roof curb adaptor to allow for bolt head clearance and curb cap tilting around the roof curb or roof curb adaptor.

1. With fan in place on roof curb, locate the hinge cap on both end, mark the holes for 5/16" diameter bolts, drill (8) 1 1/32" diameter holes at the marked locations.
2. Attach the hinge cap (items 6 & 7) to curb cap or fan using (8) 5/16" bolts & flanged nuts, locate bolt head on the inside of the curb cap.
3. With unit in place on roof curb, align curb hinge on roof curb or curb cap adaptor as shown and mark the (8) locations in the roof curb or curb adaptor**.
4. Drill (8) 1 1/32" diameter holes in previously marked hole locations.
5. Attach curb hinge to roof curb using (8) 5/16" diameter bolts.
6. You can now tilt the fan open about 60°, use the 3/8" bolt to lock the fan in place and prevent it from tipping or slamming shut.
7. Remove the locking bolt when closing back the fan in place, store the bolt next to the fan for future openings or locks.

CAUTION: Make sure to remove grease box (if applicable) when tilting the fan to prevent any spillage.

** Two hinge pivot holes are provided in the curb hinge to allow the curb hinge to be mounted higher or lower on the roof curb as required.