

# MODEL L3E (Exhaust) & L3S (Supply) SIDEWALL PROPELLER FAN - BELT DRIVE LEVEL 3 CONSTRUCTION

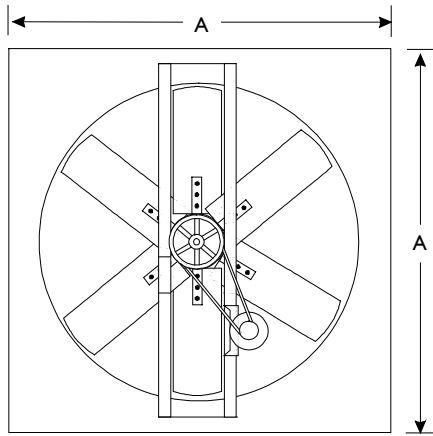

6393 Powers Avenue  
Jacksonville, Florida 32217-2298  
P: 904.731.4711 / F: 904.737.8322  
www.jencofan.com

Soler&Palau  
Ventilation Group



REAR VIEW

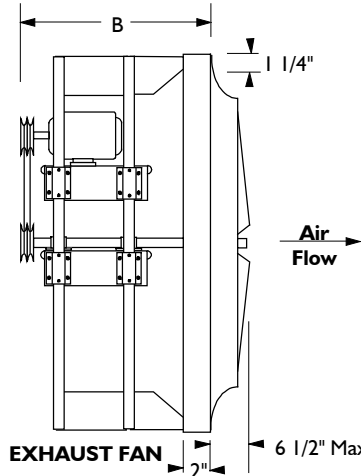

EXHAUST FAN

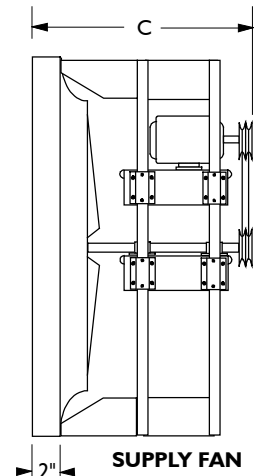

SUPPLY FAN



SIZE	A SQ. O.D. PANEL	B EXHAUST	C SUPPLY	APPROX WT.	MAX MOTOR	MATERIAL GAUGE OR THICKNESS								
						SHAFT	PANEL		SUPPORT FRAME		BLADES		HUB	PIPE FRAME
							Galv	Alum	Galv	Alum	Galv	Alum		
42	48	24	28	260	213T	1-7/16	16	.08	10	1/4	16	.08	3/8	1-1/4" OD SCHED. 40
48	54	24	28	330	215T	1-7/16	16	.100	10	1/4	16	.08	3/8	
54	60	24	28	500	254T	2-3/16	14	.100	10	1/4	16	.08	3/8	
60	66	24	28	530	256T	2-3/16	14	.100	10	1/4	16	.08	3/8	
72	80	24	28	600	256T	2-3/16	14	.100	10	1/4	16	.08	3/8	

### CONSTRUCTION AND MATERIAL SPECIFICATION - LEVEL 3

**Fan panel, motor & bearing mounts** - all welded G90 galvanized steel.

**Pipe support frame** - H.D. four post welded 1 1/4" OD schedule 40 galvanized pipe.

**Fan Blades** - G90 galvanized (multiple laminations), bolted to hub.

**Hub** - Heavy-duty welded steel, epoxy coated, keyed to shaft.

**Bearings** - Air handling, self aligning, cast iron pillow block with grease fittings, L50 = 200,000 hours average life.

**Shaft** - Turned, ground and polished, keyed to propeller hub and sheave.

**Drives** - Cast iron, 150% S.F., single groove and adjustable thru 3HP, keyed to motor and fan shaft.

**Belts** - Nonstatic conducting, oil resistant, single groove thru 3HP.

FAN SPECIFICATIONS									MOTOR SPECIFICATIONS				
Line	Qty.	Model No.	Tag	CFM	SP	Fan RPM	BHP	Sones	HP	Volts	Phase	Hertz	Encl
1													
2													
3													
4													
5													

ACCESSORY ITEMS					ACCESSORY ITEMS				
1	2	3	4	5	1	2	3	4	5
<input type="checkbox"/>					<input type="checkbox"/>				
<input type="checkbox"/>					<input type="checkbox"/>				
<input type="checkbox"/>					<input type="checkbox"/>				
<input type="checkbox"/>					<input type="checkbox"/>				
<input type="checkbox"/>					<input type="checkbox"/>				