

# WALL HOUSING

## SIDEWALL PROPELLER FANS - BELT OR DIRECT DRIVE

### MODELS LCE/LCS, L2E/L2S, L3E/L3S, DDE/DDS, DFE/DDS - EXHAUST & SUPPLY

Wall Housings are used to facilitate mounting fans with their accessories in a wall. The housing may be positioned inside or outside the building per the customer's preference or application. Typically, the wall housing for exhaust applications incorporates a damper on the exterior of the building and a guard on the interior of the building. On supply applications, a rainhood and motorized damper are highly recommended to help prevent moisture entering into the building. For installation with wall housing extending outside the building, field caulking and/or flashing of seams and unused prepunched mounting holds is required.

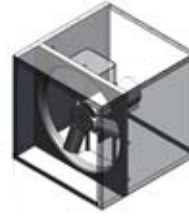

6393 Powers Avenue  
Jacksonville, FL 32217-2298  
P: 904.731.4711  
F: 904.737.8322  
www.jencofan.com



REAR VIEW  
From Motor Side

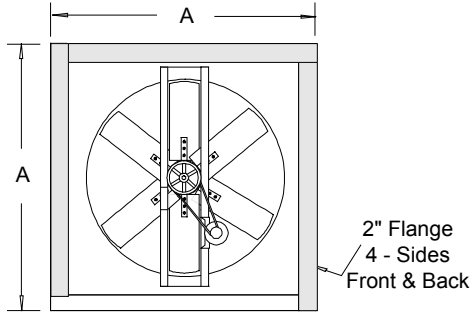

SIDE VIEW  
Shown with Motorside  
Wire Guard and  
Gravity Exhaust Damper

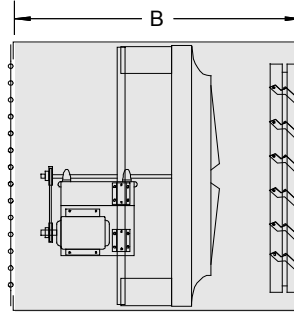

Fan Size	A (S.Q.) O.D.	Wall Housing	Minimum Wall Opening	Damper	MATERIAL SPECIFICATIONS (GAUGE OR INCHES THICK)			
		B Length	Square	D (O.D.)				
10/12	17	26	17 1/2	14 1/2	20 ga	.063	20 ga	.063
14/16	21	26	21 1/2	18 1/2	20 ga	.063	20 ga	.063
DFE/DFS18/20	25	26	25 1/2	22 1/2	20 ga	.063	20 ga	.063
LC20	25	44	25 1/2	22 1/2	20 ga	.063	20 ga	.063
24	31	44	31 1/2	28 1/2	18 ga	.080	18 ga	.080
30	37	44	37 1/2	34 1/2	18 ga	.080	18 ga	.080
36	43	44	43 1/2	40 1/2	16 ga	.080	16 ga	.080
42	49	44	49 1/2	46 1/2	16 ga	.080	16 ga	.080
48	55	44	55 1/2	52 1/2	16 ga	.080	16 ga	.080
54	61	44	61 1/2	58 1/2	14 ga	.080	14 ga	.080
60	67	44	67 1/2	64 1/2	14 ga	.080	14 ga	.080
72	81	44	81 1/2	78 1/2	14 ga	.080	14 ga	.080

**NOTES:**

- (1) Dimension "A" includes fastener heads (approx. 5/8" extra).
- (2) Wall housing ship assembled with fan unless ordered knocked down for field assembly.
- (3) Standard material is G90 galvanized. Aluminum optional.
- (4) Angle mounting flanges ship loose and are optional.
- (5) CAUTION: Housing position when mounted may require additional support (by others).
- (6) Data applies to exhaust and supply fan models unless shown otherwise.

**1 CAUTION:** When wall housing extends outside the building, field caulking and/or flashing of seams and unused prepunched mounting holes is required.

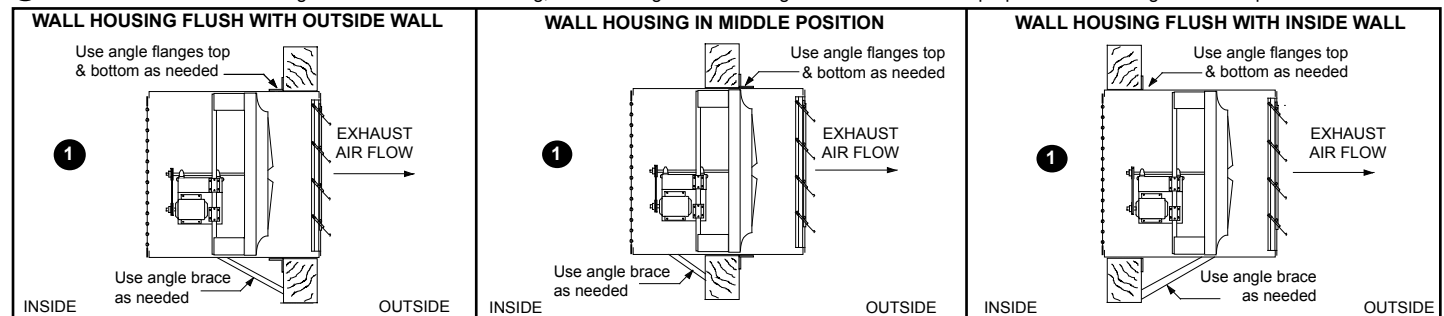

All drawings shown with Belt Drive Fan, Direct Drive dimensions do not differ unless otherwise noted.

# ASSEMBLED WALL HOUSING PACK

## SIDEWALL PROPELLER FANS - BELT OR DIRECT DRIVE

### MODELS LCE/LCS, L2E/L2S, L3E/L3S, DDE/DDS, DFE/DDS - EXHAUST & SUPPLY



This heavy-gauge, all galvanized G-90 steel housing provides a simple solution to installing a fan and all required accessories in a rough wall opening. It can be used in exhaust or supply applications. Depending on space and maintenance requirements, the wall housing maybe installed inward or outwards of the building. All housings ship with the fan, shutter and guard assembled to lessen jobsite installation costs. **Rainhoods (not included in packs) are required for all supply applications, and motorized shutters are strongly recommended.**

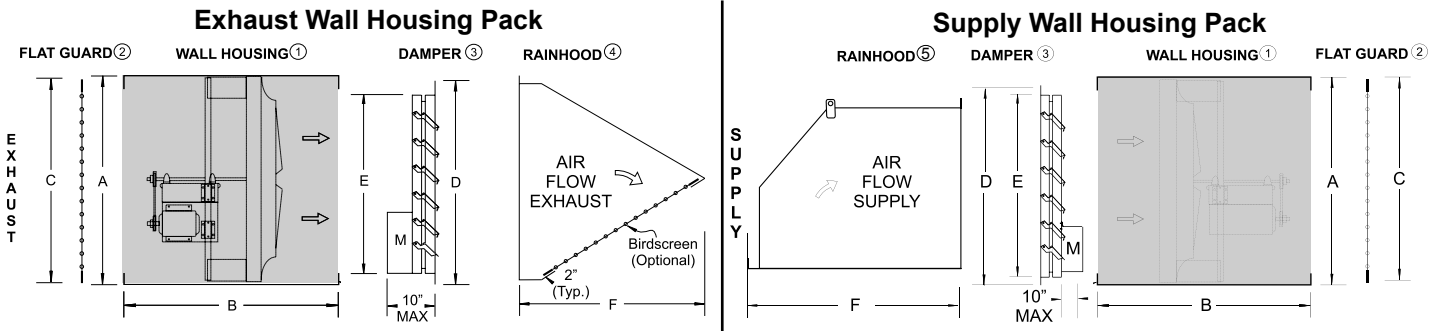

Fan Size	A (S.Q.) O.D.	Wall Housing ①	Minimum Wall Opening	Flat Guard ②	Damper ③		Exhaust	Supply			
					B Length	Square	C (SQ.)	D (O.D.)	E	Optional Rainhood 45 Deg. ④	Required Rainhood 90 Deg. ⑤
										F	F
10/12	17	26	17 1/2	16	14 1/2	12	Exh/Sup	16 1/4	-		
14/16	21	26	21 1/2	20	18 1/2	16		20 1/4	-		
18	25	26	25 1/2	24	22 1/2	20		24 1/4	-		
20	25	26	25 1/2	24	22 1/2	20	24 1/4	27 3/4			
24	31	44	31 1/2	30	28 1/2	26	28 1/2	38 1/2			
30	37	44	37 1/2	36	34 1/2	32	34 1/2	44 1/2			
36	43	44	43 1/2	42	40 1/2	38	40 1/2	49			
42	49	44	49 1/2	48	46 1/2	44	46 1/2	56 1/2			
48	55	44	55 1/2	54	52 1/2	50	49 1/2	62 1/2			
54	61	44	61 1/2	60	58 1/2	56	58 1/2	73			
60	67	44	67 1/2	66	64 1/2	62	64 1/2	73			
72	81	44	81 1/2	80	78 1/2	76	73	73			

**NOTES:**

- (1) Dimensions include fastener heads (approx 5/8" extra).
- (2) Housing ship assembled with fan unless ordered K.D.
- (3) Standard material is G90 galvanized. Aluminum optional
- (4) Angle mounting flanges ship loose and are an option.
- (5) CAUTION: Housing position when mounted may require additional support.
- (6) Data applies to exhaust and supply fan models unless shown otherwise.

**CAUTION:** When wall housing extends outside the building, field caulking and/or flashing of seams and unused prepunched mounting holes is required.

### TYPICAL MOUNTING ARRANGEMENTS

The most common mounting arrangement (below left) leaves a clean building exterior and allows access to the fan, motor and drives from inside the building. Additional bracing angle, rod or cable (field provided) should be used in addition to the mounting angles to support the fan and wall housing assembly.

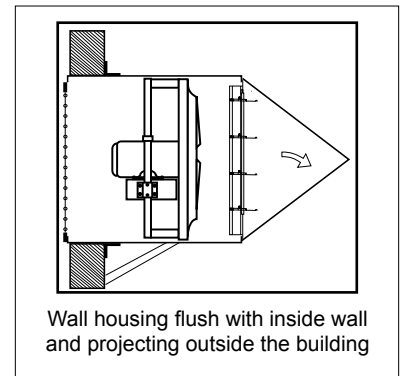
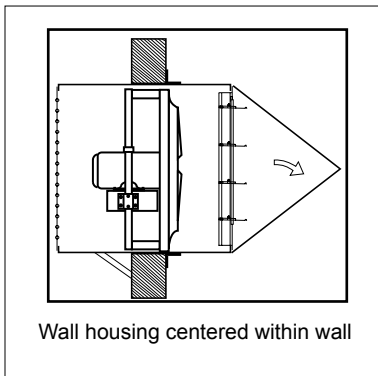
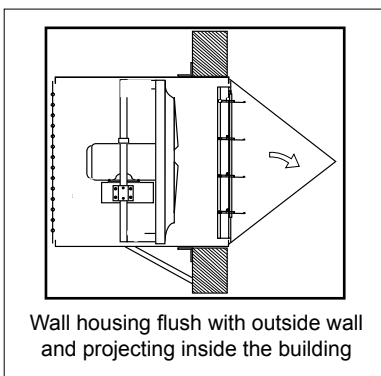

# FILTERED WALL HOUSING SIDEWALL PROPELLER FANS - BELT & DIRECT DRIVE EXHAUST & SUPPLY



6393 Powers Avenue  
Jacksonville, FL 32217-2298  
P: 904.731.4711  
F: 904.737.8322  
www.jencofan.com



## Filtered Supply

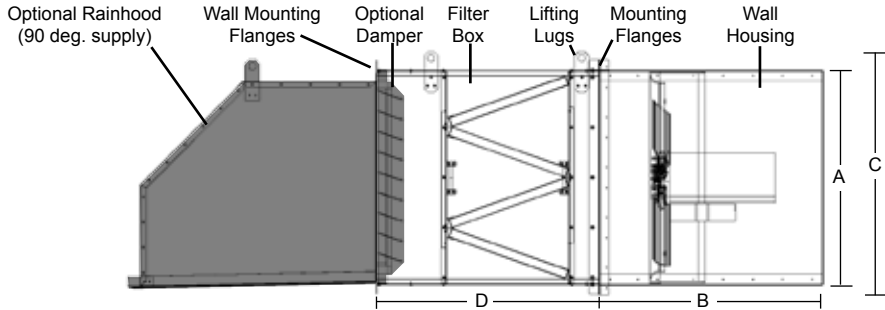

## Filtered Exhaust

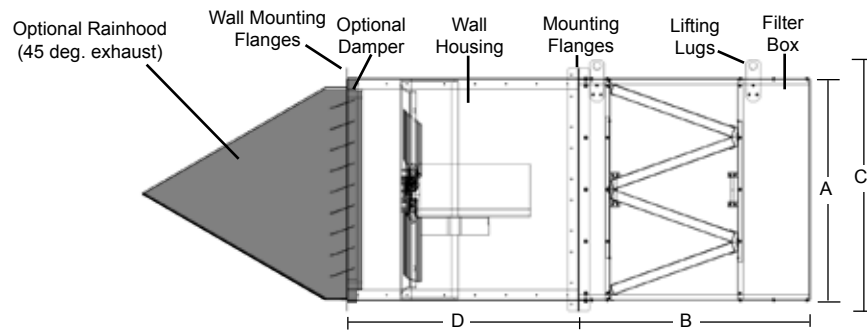

Fan Size	A (S.Q.) O.D.	Wall Housing				Minimum Wall Opening Square	Filter Box			
		B Length					C	D	# of Filters	Filter Actual Dimensions
		LC & L2	GED & DFE Only		DDE/DDS					
		Exh/Sup	Exhaust	Supply	Exh/Sup					
14/16	21	N/A	26	26	N/A	21 1/2	21	39	2	19 5/8 x 19 5/8 x 1 7/8
18/20	25	44 (20 only)	26	26	N/A	25 1/2	25	44 1/8	3	19 5/8 x 24 5/8 x 1 7/8
24	31	44	44	44	44	31 1/2	31	41 1/8	4	19 5/8 x 24 5/8 x 1 7/8
30	37	44	44	44	44	37 1/2	37	44 1/8	8	15 5/8 x 24 5/8 x 1 7/8
36	43	44	N/A	N/A	44	43 1/2	43	44 1/8	8	19 5/8 x 24 5/8 x 1 7/8
42	49	44	N/A	N/A	44	49 1/2	49	44 1/8	10	19 5/8 x 24 5/8 x 1 7/8
48	55	44	N/A	N/A	44	55 1/2	55	40 1/2	12	19 5/8 x 24 5/8 x 1 7/8
54	61	44	N/A	N/A	44	61 1/2	61	44 1/8	15	19 5/8 x 24 5/8 x 1 7/8
60	67	44	N/A	N/A	44	67 1/2	67	44 1/8	15	19 5/8 x 24 5/8 x 1 7/8

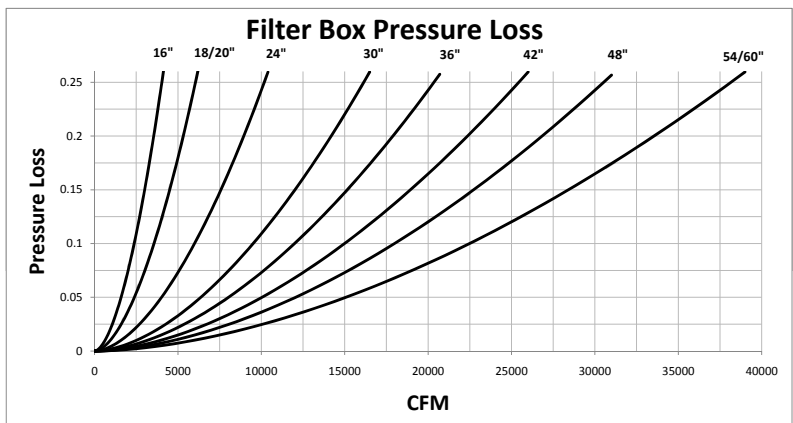

### Filter Box Parts

No	Description
1	Filter box hinged doors
2	Filter pack
3	Door Hinged Assy
4	Mounting Collar
4	5/16" -18 x 3/4" Hex HD cap screw ZP
5	5/16" Flange Nut ZP

# WALL COLLAR

## DIRECT DRIVE GED/GSD, DFE/DFS & DDE/DDS FANS

## BELT DRIVE LCE/LCS, L2E/L2S, L3E/L3S (LEVEL 1, 2 AND 3)

## EXHAUST OR SUPPLY



6393 Powers Avenue  
 Jacksonville, FL 32217-2298  
 P: 904.731.4711  
 F: 904.737.8322  
 www.jencofan.com



The G90 galvanized steel (aluminum optional) mounting collar can be used with the flat wire guard or a damper (but not both), along with a rainhood for weather protection. This accessory is not compatible with the motorside guard (see also wall housing with flat guard). OSHA safety guards are required in many installations and where the fans are within 7 feet of the floor or work/access areas.

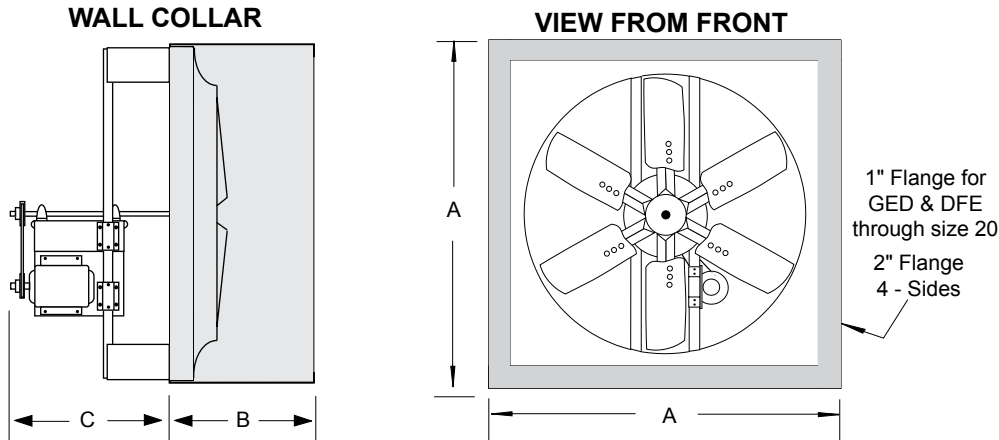

DIMENSIONS IN INCHES											
FAN SIZE	A (SQ)	B (GED, DFE/LC, L2, L3)	C (MAX)		WALL OPENING (Sq.)	MATERIAL (Ga. or Thickness)		WEIGHT (lbs.)		STANDARD DAMPER	
			EXHAUST	SUPPLY		GALV.	ALUM	GALV.	ALUM	SIZE OD	SIZE I.D.
10/12	17	16	14	16-5/8	17-1/4	20	.050	12	11	14-1/2	12
14/16	21	16	14	16-5/8	21-1/4	20	.050	14	12	18-1/2	16
18/20	25	16/21	20	24	25-1/4	20	.050	15	12	22-1/2	20
24	31	21	20	24	31-1/4	18	.050	17	14	28-1/2	26
30	37	21	20	24	37-1/4	18	.050	20	16	34-1/2	32
36	43	21	20	24	43-1/4	16	.063	24	19	40-1/2	38
42	49	21	22	26	49-1/4	16	.063	28	23	46-1/2	44
48	55	21	22	26	55-1/4	16	.063	31	25	52-1/2	50
54	61	21	22	26	61-1/4	16	.080	35	28	58-1/2	56
60	67	21	22	26	67-1/4	14	.080	40	32	64-1/2	62
72	81	26	22	26	81-1/4	12	.080	60	50	78-1/2	76

**NOTES:**

1. Wall collar ships fully assembled to fan unless specified knocked down.
2. G90 galvanized construction is standard (aluminum optional).
3. Wall collar length "B" maintains proper clearance for standard motorized shutter.
6. Dimension "A" includes fasteners (approx. 5/8").

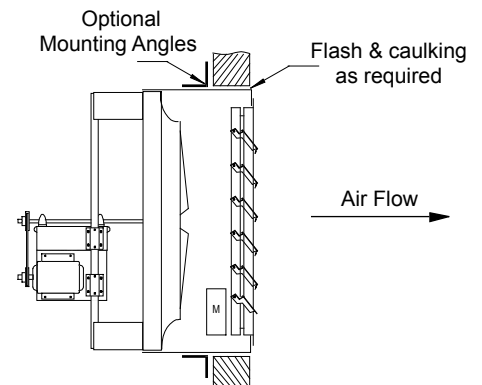

Exhaust Fan shown in Wall Collar with Motorized Damper

# SIDEWALL PROPELLER FAN - ACCESSORY SUPPLY RAINHOOD (or WEATHERHOOD)



6393 Powers Avenue  
Jacksonville, Florida 32217-2298  
P: 904.731.4711 / F: 904.737.8322  
www.jencofan.com



45 Degree

(1-1/2" Flange  
Typ. 3 sides)

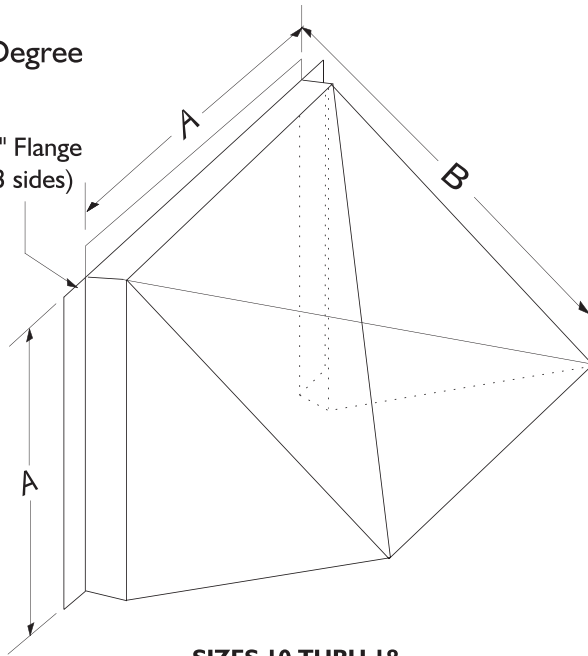

**SIZES 10 THRU 18**

90 Degree

(1-1/2" Flange  
Typ. 3 sides)

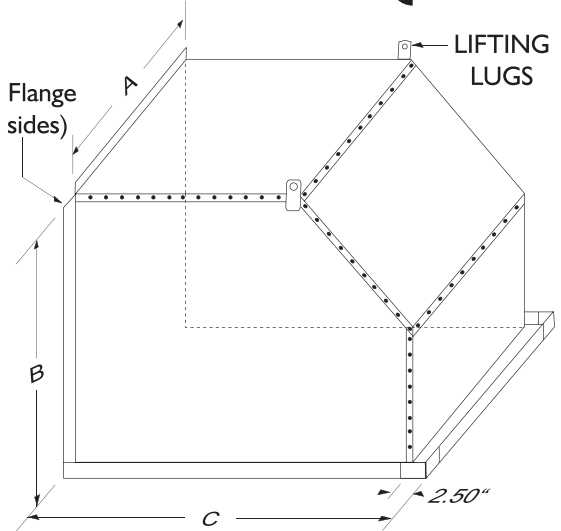

**SIZES 20 THRU 72**

Rainhoods are recommended for all supply installations and wherever additional weather protection is desired.

Rainhoods **DO NOT** guarantee that water, snow, or other airborne particles will not become entrained in the airstream and enter the building through the fan.

MODEL SIZE	A	B	C	GAUGE (2)	DEGREE	AVG. WT.
10/12	14	16-1/4	-	18	45	15
14/16	18	20-1/4	-	18	45	20
18	22	24-1/2	-	18	45	25
20	22	22	27-3/4	18	90	25
24	27-1/4	26-1/2	38-1/2	18	90	30
30	32-1/2	33-1/2	44-1/2	18	90	40
36	38-1/2	39-1/4	49	18	90	50
42	44-1/2	45-1/4	56-1/2	18	90	60
48	50-1/2	51-1/2	62-1/2	18	90	70
54	56-3/4	57	73	18	90	120
60	62-3/4	63	73	18	90	175
72	76-3/4	76-3/4	73	18	90	200

- Hoods ship in pieces (a) for field assembly unless specified otherwise. Mounting holes may require field drilling.
  - a. 3 pcs - Fan Sizes 10" to 18"
  - 7 pcs - Fan Sizes 20" to 48"
  - 13 pcs - Fan Sizes 54" to 72"
- Standard construction is G90 galvanized steel.
- Hoods are sized to fit standard wall housings.
- Rainhoods do not guarantee water will not enter through opening.
- Optional birdscreen is recommended to prevent critters or debris from entering the fan.

ACCESSORY ITEMS	1	2	3	4	5	ACCESSORY ITEMS	1	2	3	4	5
<input type="checkbox"/>						<input type="checkbox"/>					
<input type="checkbox"/>						<input type="checkbox"/>					
<input type="checkbox"/>						<input type="checkbox"/>					
<input type="checkbox"/>						<input type="checkbox"/>					
<input type="checkbox"/>						<input type="checkbox"/>					

Project: \_\_\_\_\_ Submitted: \_\_\_\_\_  
 Customer: \_\_\_\_\_ Approved: \_\_\_\_\_  
 Location: \_\_\_\_\_

# SIDEWALL PROPELLER FAN - ACCESSORY 45 DEGREE RAINHOOD (or WEATHERHOOD) FOR EXHAUST APPLICATIONS ONLY



6393 Powers Avenue  
Jacksonville, Florida 32217-2298  
P: 904.731.4711 / F: 904.737.8322  
www.jencofan.com

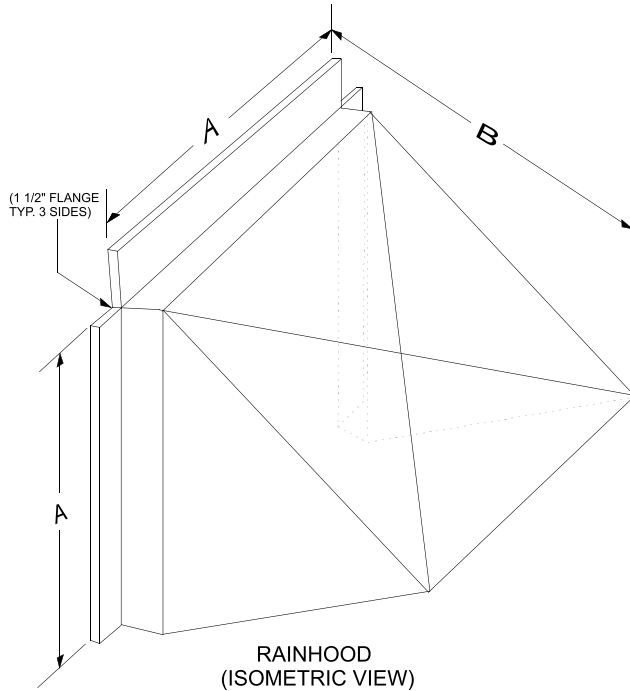

Rainhoods are recommended for all supply installations and wherever additional weather protection is desired. Refer to supply style rainhood for supply installations.

Rainhoods do not guarantee that water, snow, or other airborne particles will not become entrained in the airstream and enter the building through the fan.

- Hoods ship in several pieces for field assembly unless specified factory assembled. Mounting holes may required field drilling.
- Standard construction is G90 galvanized steel.
- Hoods are sized to fit standard wall housings.
- Rainhoods do not guarantee water will not enter through opening.
- Sizes 48" and larger have support angles fastened to front edge.
- Optional birdscreen is recommended to prevent critters or debris from entering the fan.

MODEL SIZE	A	B	GAUGE (2)	AVG. WT.
10/12	14	16-1/4	18	15
14/16	18	20-1/4	18	20
18	22	24-1/4	18	25
20	22	24-1/4	18	25
24	28	28-1/2	18	30
30	34	34-1/2	18	40
36	40	40-1/2	18	50
42	46	46-1/2	18	60
48	52	49-1/2	16	70
54	58	58-1/2	16	120
60	64	64-1/2	16	175
72	78	64-1/2	16	200

ACCESSORY ITEMS	1	2	3	4	5	ACCESSORY ITEMS	1	2	3	4	5
<input type="checkbox"/>						<input type="checkbox"/>					
<input type="checkbox"/>						<input type="checkbox"/>					
<input type="checkbox"/>						<input type="checkbox"/>					
<input type="checkbox"/>						<input type="checkbox"/>					
<input type="checkbox"/>						<input type="checkbox"/>					

Project: \_\_\_\_\_ Submitted: \_\_\_\_\_  
 Customer: \_\_\_\_\_ Approved: \_\_\_\_\_  
 Location: \_\_\_\_\_

# SIDEWALL PROPELLER FAN ACCESSORY RAINHOOD - K.D. (Knocked Down) FOR FIELD ASSEMBLY



6393 Powers Avenue  
Jacksonville, Florida 32217-2298  
P: 904.731.4711 / F: 904.737.8322  
www.jencofan.com

Soler&Palau  
Ventilation Group

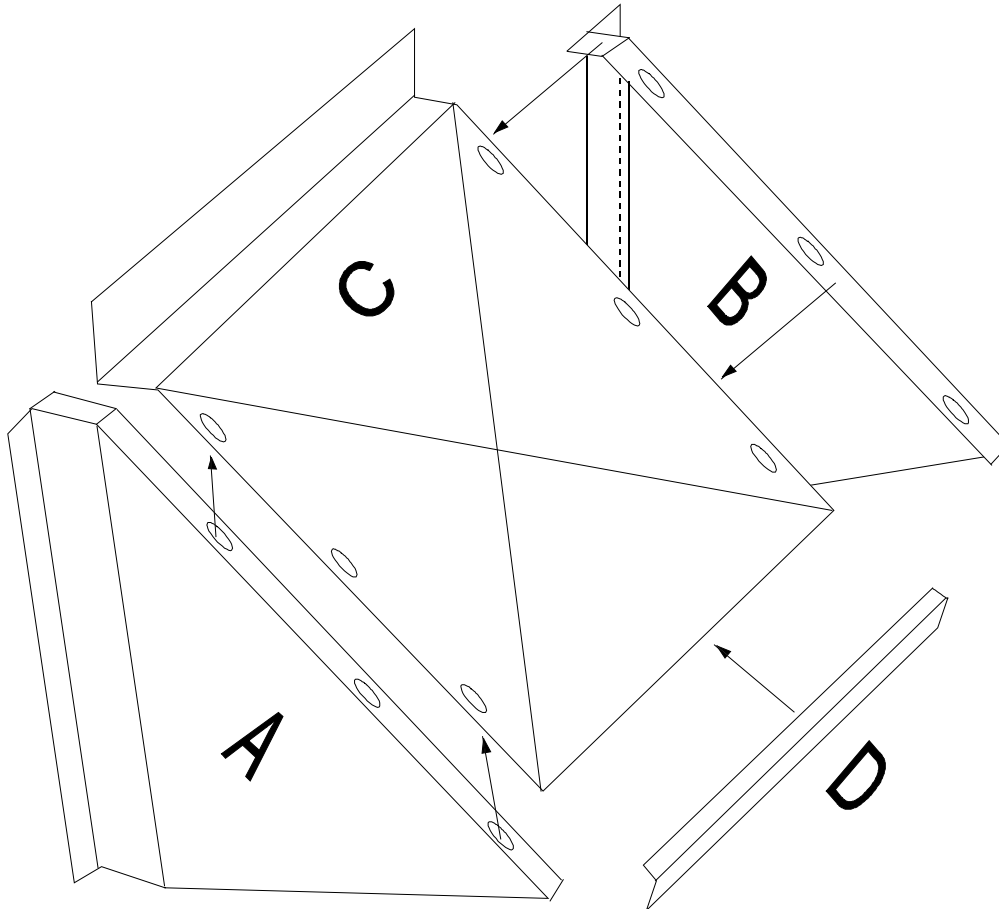

## ASSEMBLY INSTRUCTION FOR KNOCKED DOWN RAINHOODS

1. Align side "A" with top (C).
2. Fasten securely with 1/4" sheet metal screws provided.
3. Attach side "B" following the same steps.
4. On sizes 48" and larger, attached support angle (D) to front edge as shown, with sheet metal screws provided.
5. Attach (optional) wire birdguard (when purchased) to factory flanges/rain channels or to field provided 1 1/2" X 1 1/2" galvanized formed angle (approx. 18 ga.).
6. Securely fasten to factory wall box flanges (drill as required) and thoroughly flash and caulk wall opening and seams.

# BACKDRAFT DAMPER FOR SIDEWALL PROPELLER (EXHAUST/SUPPLY)



6393 Powers Avenue  
Jacksonville, Florida 32217-2298  
P: 904.731.4711 / F: 904.737.8322  
www.jencofan.com

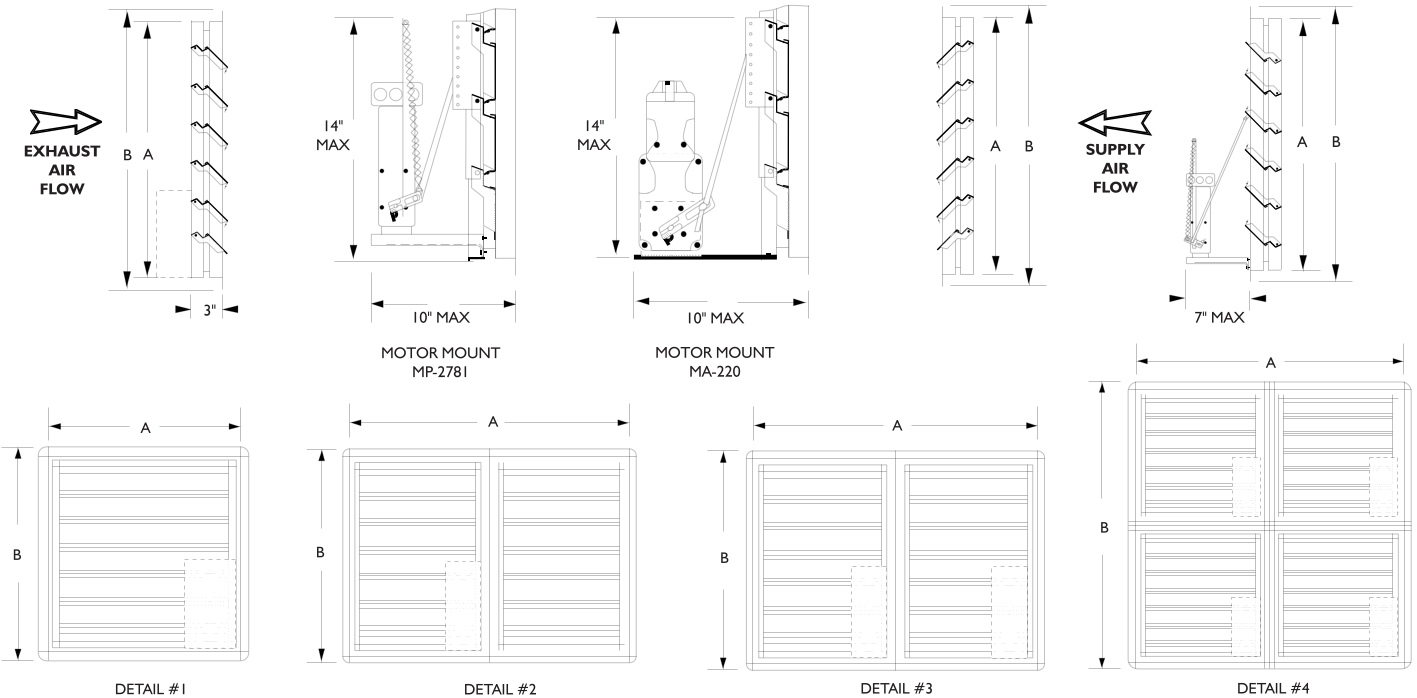

Fan Size	A Square Size	B Sq. OD Flange	Panels (Detail)	Motor Type			
				Exhaust		Supply	
				Type	Qty	Type	Qty
10-12	12	14 1/2	1	MP-2781	1	MP-2781-S	1
14-16	16	18 1/2	1	MP-2781	1	MP-2781-S	1
18-20	20	22 1/2	1	MP-2781	1	MP-2781-S	1
24	26	28 1/2	1	MP-2781	1	MP-2781-S	1
30	32	34 1/2	1	MP-2781	1	MA-220-S	1
36	38	40 1/2	1	MA-220	1	MA-220-S	1
42	44	46 1/2	2	MA-220	1	MA-220-S	2
48	50	52 1/2	2	MA-220	1	MA-220-S	2
54	56	58 1/2	3	MA-220	2	MA-220-S	2
60	62	64 1/2	3	MA-220	2	MA-220-S	2
72	77	79 1/2	4	MA-220	4	MA-220-S	4

### STANDARD SPECIFICATIONS:

Maximum Face Velocity: 3000 fpm.  
Temperature limits: -40°F to 200°F (-40°C to 94°C)  
Minimum Size: 8 x 8  
Size: Single section: 42 x 64 Max W/H  
Multiple section assembly - Unlimited size.  
Frame: 20 gauge galvanized steel.  
Blades: .025 thick aluminum.  
HD 28 gauge galvanized steel.  
Seals: Extruded vinyl mechanically locked into blades.  
Axles: Stainless Steel.  
Linkage: Stainless steel pins, galvanized steel tie bar.  
Finish: Mill.

**CAUTION:** Motor kits are not suitable for use in explosive or flammable areas or airflows.

Multiple section dampers are factory assembled (except 72" and larger).

For all **supply applications**, a rainhood and motor kit is recommended.

### NOTES:

- (1) Do not mount fan less than 12 inches from the shutter.
- (2) Motors available in 24V, 120V, 240V & 440V.
- (3) Dampers shipped in individual cartons.
- (4) Motors and mounting hardware ship separately.
- (5) Center-pivoted dampers must be used on reversible fans.
- (6) Multiple section assemblies may require bracing to support the weight of the assembly and to hold against system pressure. **BRACING SUPPLIED BY OTHERS.**

Heavy-duty Dampers required on all units with 7 1/2HP motors and above.

ACCESSORY ITEMS	1	2	3	4	5	ACCESSORY ITEMS	1	2	3	4	5
<input type="checkbox"/>						<input type="checkbox"/>					
<input type="checkbox"/>						<input type="checkbox"/>					
<input type="checkbox"/>						<input type="checkbox"/>					
<input type="checkbox"/>						<input type="checkbox"/>					
<input type="checkbox"/>						<input type="checkbox"/>					

Project: \_\_\_\_\_ Submitted: \_\_\_\_\_  
 Customer: \_\_\_\_\_ Approved: \_\_\_\_\_  
 Location: \_\_\_\_\_

# CENTER PIVOT MOTORIZED DAMPER EXHAUST OR SUPPLY VERTICAL OR HORIZONTAL AIR FLOW



6393 Powers Avenue  
Jacksonville, Florida 32217-2298  
P: 904.731.4711 / F: 904.737.8322  
www.jencofan.com

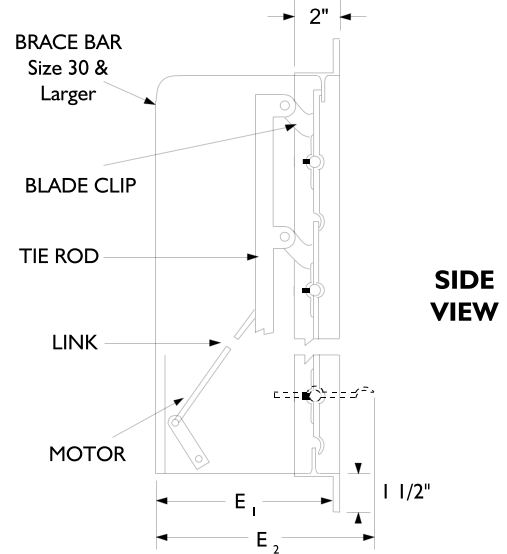
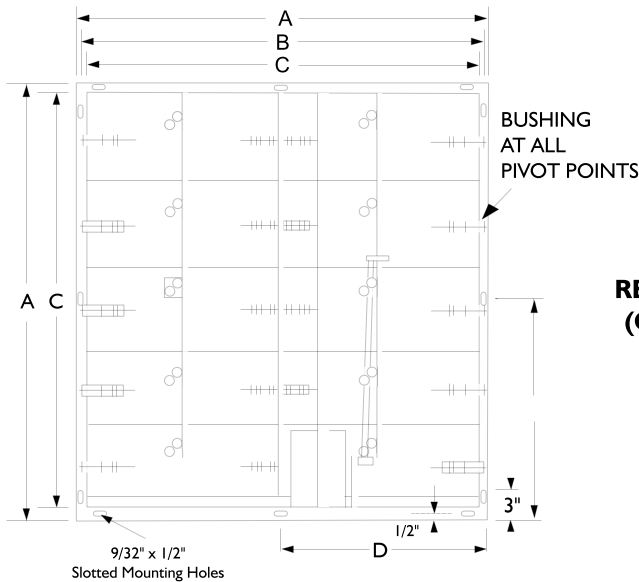

**GALVANIZED STEEL CONSTRUCTION  
FRAME IS 14 GAUGE**

- 16 Gauge galvanized steel center pivoted blades, open to a full 90° to allow full air flow.
- 1/8 inch thick galvanized tie rod and attaching blade clip.
- Galvanized dampers have 1/2 inch diameter plated steel pivot shaft with brass grommet bushing.

**ALUMINUM CONSTRUCTION  
FRAME IS 1/8 INCH THICK EXTRUDED**

- Extruded aluminum blades with nylon bushings are .080 thick center pivoted to allow full 90° opening.
- 1/8" thick aluminum tie rod and attaching blade clip.

**GALVANIZED AND ALUMINUM DAMPERS**

- All dampers can be used for intake or exhaust applications.
- All dampers are factory motorized, 120/240 dual voltage single phase motor, power open-spring close.
- Ample 9/32" x 1/2" slotted mounting holes in 1 1/2" flange.
- Sizes larger than 48" wide are double panel - factory joined.
- Max velocity - 3000 FPM.
- Max differential pressure - 2" W.G.

FAN SIZE	OPENING REQUIRED	A O.D.	B (l)	C "Size"	D (Center of Holes)	# OF PANELS	G		MOTOR (2)		
							CLOSED (E-1)	OPEN (E-2)	POWER SUPPLY	MAX AMPS	STALL TORQUE (in. lbs)
24	27	29	24-1/2	26	-	1 x 1	7-1/4	8-1/2	120-240V 60Hz	0.3/0.6	25
30	33	35	30-1/2	32	-	1 x 1	10-1/4	13-3/4		0.3/0.6	25
36	39	41	36-1/2	38	19-1/2	1 x 1	10-1/4	13-3/4		0.3/0.6	25
42	45	47	42-1/2	44	22-1/2	1 x 1	10-1/4	13-3/4		0.3/0.6	25
48	51	53	48-1/2	50	25-1/2	2 x 1	10-1/4	13-3/4		0.3/0.6	25
54	57	59	54-1/2	56	28-1/2	2 x 1	10-1/4	12-3/4	240V 60Hz	0.5	60
60	63	65	60-1/2	62	31-1/2	2 x 1	10-1/4	12-3/4		0.5	60
72	77	79	76-1/2	76	39-1/2	2 x 1	10-1/4	12-3/4		0.5	60

(1) Minimum opening to clear pins.  
(2) Motor is 60 Hz, single phase continuous duty with 104°F (40°C), maximum ambient temperature

**NOT SUITABLE FOR USE IN HAZARDOUS OR FLAMMABLE AREAS OR AIRSTREAMS.**

ACCESSORY ITEMS	1	2	3	4	5	ACCESSORY ITEMS	1	2	3	4	5
<input type="checkbox"/>						<input type="checkbox"/>					
<input type="checkbox"/>						<input type="checkbox"/>					
<input type="checkbox"/>						<input type="checkbox"/>					
<input type="checkbox"/>						<input type="checkbox"/>					
<input type="checkbox"/>						<input type="checkbox"/>					

# ASSEMBLY INSTRUCTIONS FOR WALL BOX/HOUSING



6393 Powers Avenue  
Jacksonville, Florida 32217-2298  
P: 904.731.4711 / F: 904.737.8322  
www.jencofan.com

Soler&Palau  
Ventilation Group

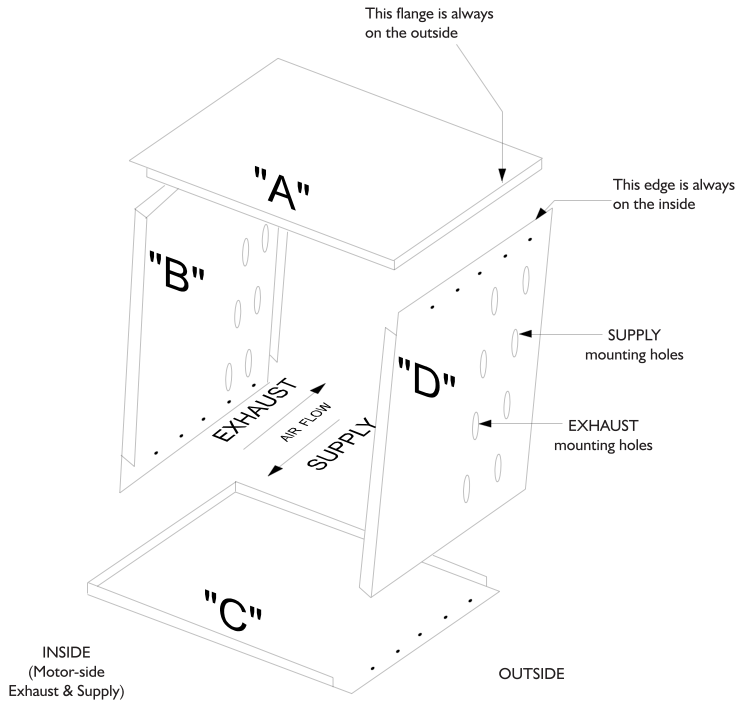

## INSTRUCTIONS

1. Assemble pieces "A", "B" and "C" with flanges on the outside. Use fasteners provided.
2. Install fan in proper exhaust or supply location maintaining the required distance between fan and shutter (if shutter is used).
3. Attach side "D".
4. Install wall box in wall with accessory angles, flat flanges or by other means as needed.

RAINFOODS ARE RECOMMENDED FOR ALL SUPPLY APPLICATIONS AND FOR ADDITIONAL WEATHER PROTECTION FOR EXHAUST APPLICATIONS.

## TYPICAL WALL BOX/HOUSING INSTALLATION

MODEL SIZE	MINIMUM WALL OPENING
10/12	17-1/2
14/16	21-1/2
18/20	25-1/2
24	31-1/2
30	37-1/2
36	43-1/2
42	49-1/2
48	55-1/2
54	61-1/2
60	67-1/2
72	81-1/2

All dimensions are shown in inches.

## Other Accessories

- Rainhoods
- Motorized Dampers
- Automatic Dampers
- Epoxy and Other
- Various Paint Finishes
- Mounting Angles
- Electrical Switches
- Safety Guards

**CAUTION:** When wall housing extends outside the building, field caulking and/or flashing of seams and unused prepunched mounting holes is required.

