

# WALL MOUNTING KIT ASSEMBLY INSTRUCTIONS

## MODELS: TXBW & TXDW



6393 Powers Avenue  
Jacksonville, Florida 32217-2298  
P: 904.731.4711 / F: 904.737.8322  
www.jencofan.com

Soler&Palau  
Ventilation Group

The centrifugal power roof ventilators model TXB (belt drive) and TXD (direct drive) can be factory ordered as wall mount or converted to wall mount units by field installing internal motor/bracket gusset and/or an external shroud support strap.

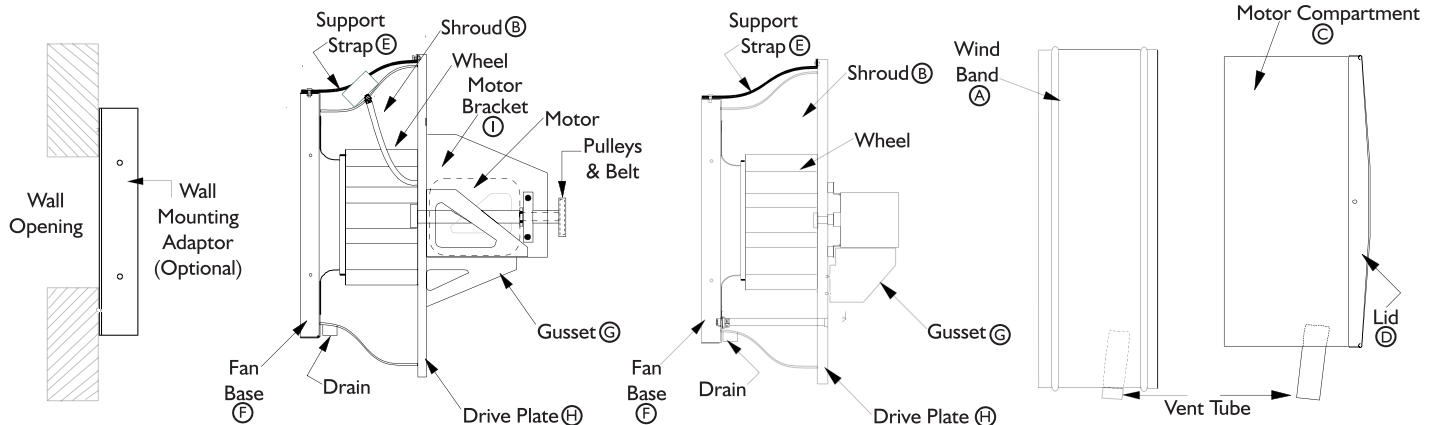

### PARTS LIST - PART # (QTY)

TXB WALL MOUNT KITS (BELT DRIVE)		TXD WALL MOUNT KITS (DIRECT DRIVE)	
Kit includes: Wall mount strap, gusset, upper support strap, flange nuts & bolts	Optional Wall Mount Adaptor	Kit includes: Wall mount gusset, upper support strap and flange bolts.	Optional Wall Mount Adaptor
6 & 8	#100401	700708-2	6 (1) #100409
10	#100402	700708-2	8 (1) #100408
12 & 15	#100403	700709-2	10 #100406
18 & 20	#100404	700710-2	12, 14, 15 #100407
24	#100405	700711-2	1515 #100410

(1) Gusset not required on TXD 6" & 8" units.

### INSTALLATION / ASSEMBLY INSTRUCTIONS:

Disconnect electrical power before servicing or assembling. Place the unit on a table or other stable surface.

1. Remove cotter pin & slide vent tube out.
2. Remove windband (A) from lower shroud (B) by removing eight (8) number 14 SS screws.
3. Remove motor compartment (C) and Lid (D) by removing four (4) number 14 SS screws.
4. Attach support strap (E) to fan base (F) by bolting thru the fan base with a 5/16 bolt & locking in place with a 5/16 nut on the outside of base.
5. To attach top end of support strap (E) to shroud by placing 5/16 bolt thru strap and shroud, then lock in place with 5/16 nut on the inside of shroud flange.
6. Attach gusset (G) to motor drive plate (H) (direct drive). Attach gusset (G) to drive support plate (H) (belt drive) and to motor bracket (I) with 5/16 X 1" bolts. Bolt the direct drive gusset to the drive plate only.
7. Bolt belt drive gusset to drive plate with bolt coming thru the drive plate and the locknut on top side of drive plate and gusset.
8. Re-assemble housing (steps 3, 2 then 1) using care not to damage the threaded fasteners by overtightening.

Only a qualified professional should perform the fan installation. **IMPORTANT:** The fan must be installed with the drain and vent tube on the underside of the fan for weather protection and proper operation.

For additional safety precautions please refer to AMCA Bulletin #410 "Recommended Safety Practices for Users and Installers of Industrial and Commercial Fans".

# INSULATED CANTED ROOF CURB NON-PROPELLER PRODUCTS



6393 Powers Avenue  
Jacksonville, Florida 32217-2298  
P: 904.731.4711 / F: 904.737.8322  
www.jencofan.com

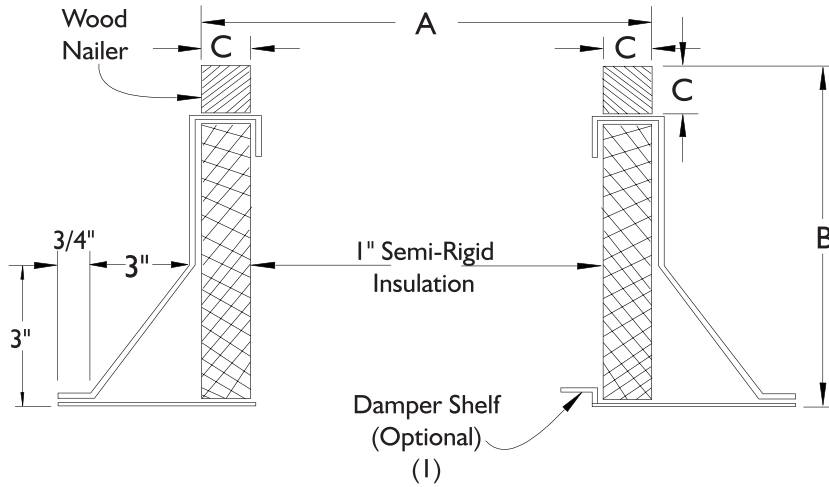

**OPTIONS:**

1. Damper Shelf.
2. Insulation retainers - solid or screen type.
3. Burglar bars - 1/2" dia. on 6" centers.
4. Finishes - baked or air-dried enamel or epoxy.
5. Heights: 8, 12, 16, 18, 20, 24" or special heights.
6. Single pitch or double pitch.
7. Aluminum construction.
8. Standard curb is "RF" roof over type. ("SF" available upon request)

FAN SIZE	"A" OD (Square) CURB					DB		"B" CURB HEIGHT	"C" WOOD NAILER
	TXB	TXD	NBRTD	RCX I I	RED / LPD	FAN SIZE	CURB OD "A"		
6	-	14-3/4	-	-	14-3/4	6	14-3/4	12" STD	1-1/2" Sq
8	14-3/4	14-3/4	-	14-3/4	14-3/4	8	14-3/4		
10	14-3/4	14-3/4	-	14-3/4	14-3/4	9	14-3/4		
12	22-1/4	22-1/4	-	22-1/4	22-1/4	11	22-1/4		
14	-	-	18-1/2	-	-	-	-		
15	22-1/4	22-1/4	-	22-1/4	22-1/4	12	22-1/4		
18	27-3/4	-	22-1/2	27-3/4	-	14	22-1/4		
20	-	-	-	27-3/4	-	16	22-1/4		
24	33-3/4	-	28-1/2	33-3/4	-	18	27-3/4		
26	-	-	-	33-3/4	-	20	27-3/4		
30	40-3/4	-	-	40-3/4	-	24	33-3/4		
33	-	-	-	40-3/4	-	30	40-3/4		
36	40-3/4	-	-	40-3/4	-	34	40-3/4		
42	53-1/4	-	-	-	-	42	53-1/4		
48	53-1/4	-	-	-	-	48	53-1/4		

1. Damper shelf opening to be 1" less than damper size. Shelf must be specified if required.
2. All curbs are 18 gauge G-90 galvanized steel with continuous seams.
3. See current curb submittal for all propeller fan roof curbs.

ROOF OPENING  
Curb O.D. (A Dimension) Less 3.25 inches

ACCESSORY ITEMS	1	2	3	4	5	ACCESSORY ITEMS	1	2	3	4	5
<input type="checkbox"/>						<input type="checkbox"/>					
<input type="checkbox"/>						<input type="checkbox"/>					
<input type="checkbox"/>						<input type="checkbox"/>					
<input type="checkbox"/>						<input type="checkbox"/>					
<input type="checkbox"/>						<input type="checkbox"/>					

Project: \_\_\_\_\_ Submitted: \_\_\_\_\_  
 Customer: \_\_\_\_\_ Approved: \_\_\_\_\_  
 Location: \_\_\_\_\_

# TYPE RFR SPECIAL RESTAURANT CURBS ROOF-OVER-FLASHING TYPE



6393 Powers Avenue  
Jacksonville, Florida 32217-2298  
P: 904.731.4711 / F: 904.737.8322  
www.jencofan.com



## STANDARD FEATURES

- Constructed of 18 ga. galv. steel with continuous welded seams and integral base plate for water tightness and extra strength.
- Large 3" built-in 45° cant to accommodate roofing to top of curb.
- Welded corners have beveled cants for better lay of materials at corners.
- Insulation not furnished when curb is equipped with special ventilation slots.
- Top ledge covered with 1/4" polystyrene gasket for weather seal and to reduce metal conducted noise.
- Minimum curb height is 18" to comply with NFPA Bulletin 96.

## OPTIONS

- Constructed of .063" aluminum.
- Interior metal liner.
- 1-1/2" glass fiber insulation (not available if sides vented).
- Optional 4" x 1/2" vent louvers - 1 to 4 sides.
- Any height.
- Raised cant 1-1/2" to 4".
- Protective or decorative coatings.
- Heavy-gauge construction.

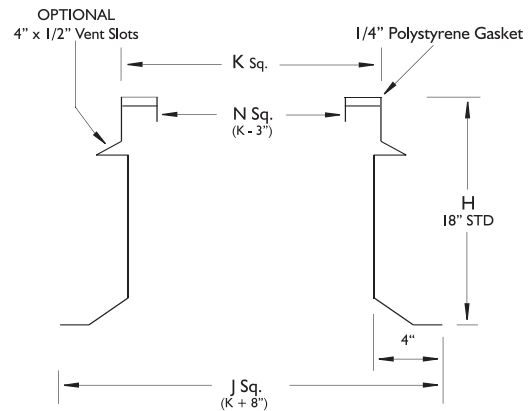
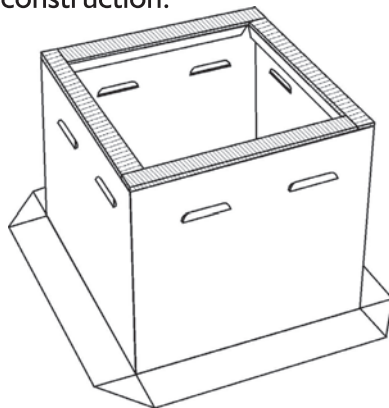

PROJECT	
LOCATION	
ARCHITECT	
ENGINEER	
CONTRACTOR	
SUBMITTED BY	
DATE	PO. NO.

## SPECIFICATIONS AND DIMENSIONS

REFERENCE	QUANTITY	GALV. OR ALUM.	K	N	H	OPTIONS

# TYPE SF SELF-FLASHING CURB



6393 Powers Avenue  
Jacksonville, Florida 32217-2298  
P: 904.731.4711 / F: 904.737.8322  
www.jencofan.com

Soler&Palau  
Ventilation Group

## STANDARD FEATURES

- Constructed of 18 ga. galv. steel with continuous welded seams and integral base plate for water tightness and extra strength.
- Wide base flashing to insure adequate bond to roofing surface for water tight seal to roof.
- Lined with 1-1/2" fiberglass fire proof sound attenuating thermal insulation.
- Top of curb covered with 1/4" polystyrene gasket for weather seal and to reduce metal to metal conducted noise.

PROJECT	
LOCATION	
ARCHITECT	
ENGINEER	
CONTRACTOR	
SUBMITTED BY	
DATE	P.O. NO.

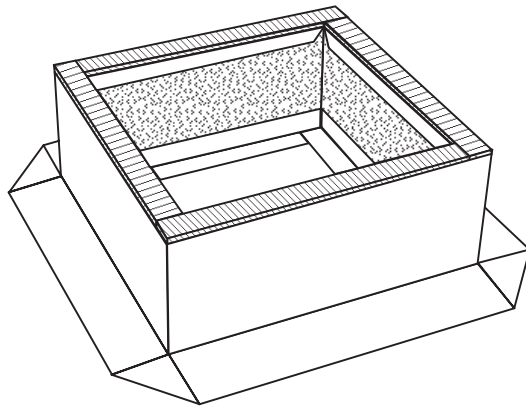
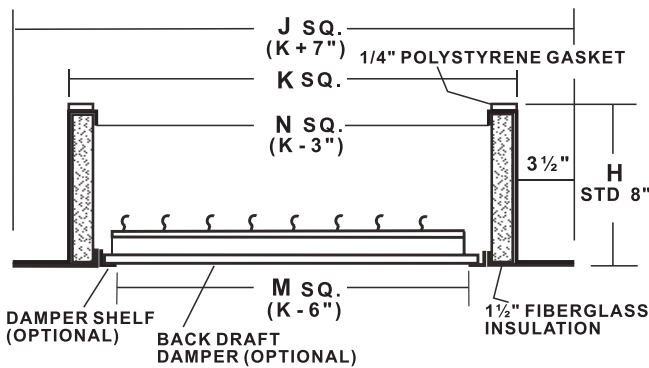

## OPTIONS

- Constructed of .063" aluminum.
- Interior metal liner.
- Standard heights of 12, 14, 16, 18, 20, 24", or any special height.
- Damper shelf - standard or custom size opening.
- Wide flange (6" or 8" wide).
- Backdraft damper.
- Protective or decorative coatings.
- Heavy-gauge construction.

## SPECIFICATIONS AND DIMENSIONS

REFERENCE	QUANTITY	GALV. OR ALUM.	K	N	M	H	OPTIONS

# TYPE RFR SPECIAL RESTAURANT CURBS ROOF-OVER-FLASHING TYPE



6393 Powers Avenue  
Jacksonville, Florida 32217-2298  
P: 904.731.4711 / F: 904.737.8322  
www.jencofan.com



## STANDARD FEATURES

- Constructed of 18 ga. galv. steel with continuous welded seams and integral base plate for water tightness and extra strength.
- Large 3" built-in 45° cant to accommodate roofing to top of curb.
- Welded corners have beveled cants for better lay of materials at corners.
- Insulation not furnished when curb is equipped with special ventilation slots.
- Top ledge covered with 1/4" polystyrene gasket for weather seal and to reduce metal conducted noise.
- Minimum curb height is 18" to comply with NFPA Bulletin 96.

## OPTIONS

- Constructed of .063" aluminum.
- Interior metal liner.
- 1-1/2" glass fiber insulation (not available if sides vented).
- Optional 4" x 1/2" vent louvers - 1 to 4 sides.
- Any height.
- Raised cant 1-1/2" to 4".
- Protective or decorative coatings.
- Heavy-gauge construction.

PROJECT	
LOCATION	
ARCHITECT	
ENGINEER	
CONTRACTOR	
SUBMITTED BY	
DATE	PO. NO.

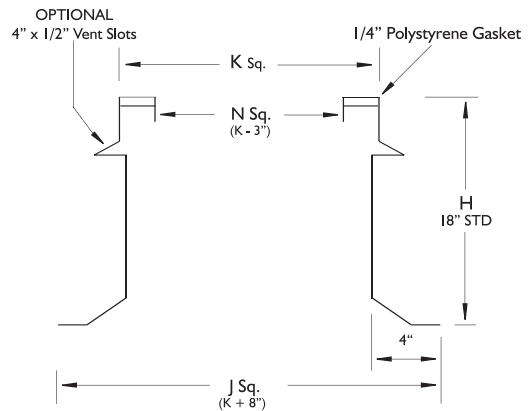
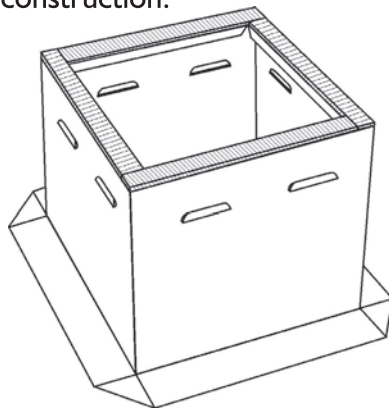

## SPECIFICATIONS AND DIMENSIONS

REFERENCE	QUANTITY	GALV. OR ALUM.	K	N	H	OPTIONS

**CURB CAP ADAPTOR  
SPUN PRODUCTS ONLY  
(+ or - 4 inches)  
Square ONLY - NO Rectangles**



6393 Powers Avenue  
Jacksonville, Florida 32217-2298  
P: 904.731.4711 / F: 904.737.8322  
www.jencofan.com

Soler&Palau  
Ventilation Group

**STANDARD FEATURES**

- Heavy-gauge aluminum construction with continuous welded seams for water tightness and extra strength.

PROJECT	
LOCATION	
ARCHITECT	
ENGINEER	
CONTRACTOR	
SUBMITTED BY	
DATE	P.O. NO.

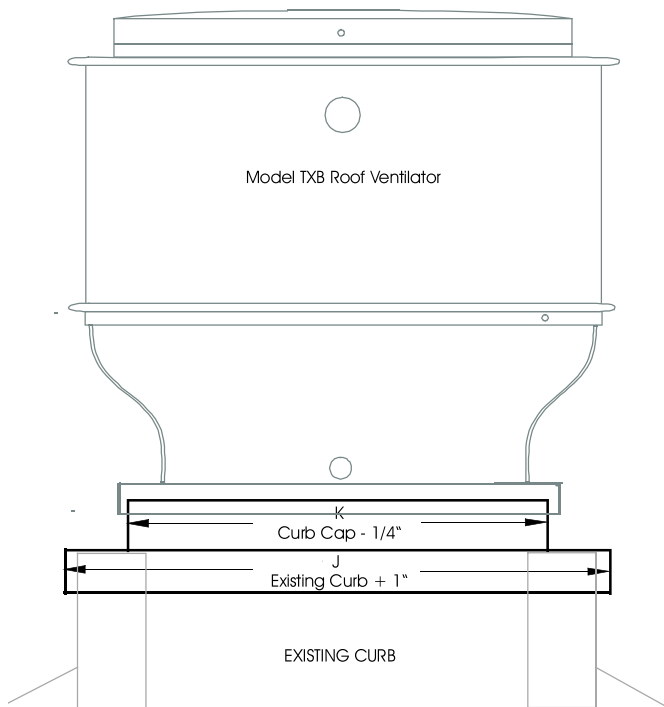

**K - MEASUREMENT**

1/4" LESS THAN FAN BASE

**J - MEASUREMENT**

1" LARGER THAN EXISTING CURB O.D.

SPECIFICATIONS AND DIMENSIONS				
REFERENCE	QUANTITY	K	J	OPTIONS

# CURB HINGE ACCESSORY



6393 Powers Avenue  
 Jacksonville, Florida 32217-2298  
 P: 904.731.4711 / F: 904.737.8322  
 www.jencofan.com  
 Soler&Palau Ventilation Group

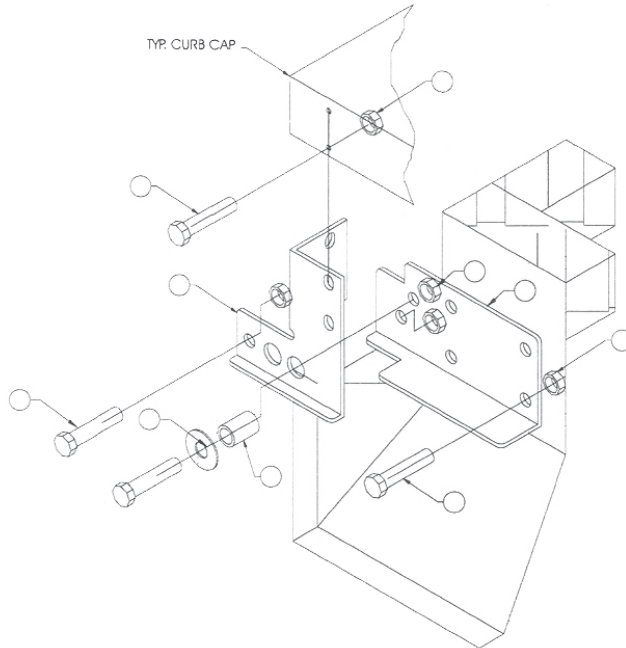

ITEM #	PART #	DESCRIPTION	QTY	ITEM #	PART #	DESCRIPTION	QTY
1	634012	3/8" Flat Washer	2	6	90005802	Hinge Bracket Left Half	1
2	634025	3/8-16 Loknut	2	7	90005101	Curb Hinge Bracket Right	1
3	603656	3/8 x 1-1/4" Long Spacer	2	8	634002	5/16-18 x 3/4 Hex Bolt	16
4	634138	3/8-16 x 2" Long Bolt	4	9	634027	5/16-18 Flange Nut	16
5	90005702	Hinge Bracket Right Half	1	10	90005201	Curb Hinge Bracket Left*	1
				11	634028	1 3/8-16 Flange Nut	2

\*Items on opposite side, not shown

**Note:** Curb cap needs to be 1/2" minimum larger than the roof curb or roof curb adaptor to allow for bolt head clearance and curb cap tilting around the roof curb or roof curb adaptor.

1. With fan in place on roof curb, locate the hinge cap on both end, mark the holes for 5/16" diameter bolts, drill (8) 1 1/32" diameter holes at the marked locations.
2. Attach the hinge cap (items 6 & 7 ) to curb cap or fan using (8) 5/16" bolts & flanged nuts, locate bolt head on the inside of the curb cap.
3. With unit in place on roof curb, align curb hinge on roof curb or curb cap adaptor as shown and mark the (8) locations in the roof curb or curb adaptor\*\*.
4. Drill (8) 1 1/32" diameter holes in previously marked hole locations.
5. Attach curb hinge to roof curb using (8) 5/16" diameter bolts.
6. You can now tilt the fan open about 60°, use the 3/8" bolt to lock the fan in place and prevent it from tipping or slamming shut.
7. Remove the locking bolt when closing back the fan in place, store the bolt next to the fan for future openings or locks.

**CAUTION:** Make sure to remove grease box (if applicable) when tilting the fan to prevent any spillage.

\*\* Two hinge pivot holes are provided in the curb hinge to allow the curb hinge to be mounted higher or lower on the roof curb as required.

# CURB HINGE ACCESSORY



6393 Powers Avenue  
 Jacksonville, Florida 32217-2298  
 P: 904.731.4711 / F: 904.737.8322  
 www.jencofan.com  
 Soler&Palau Ventilation Group

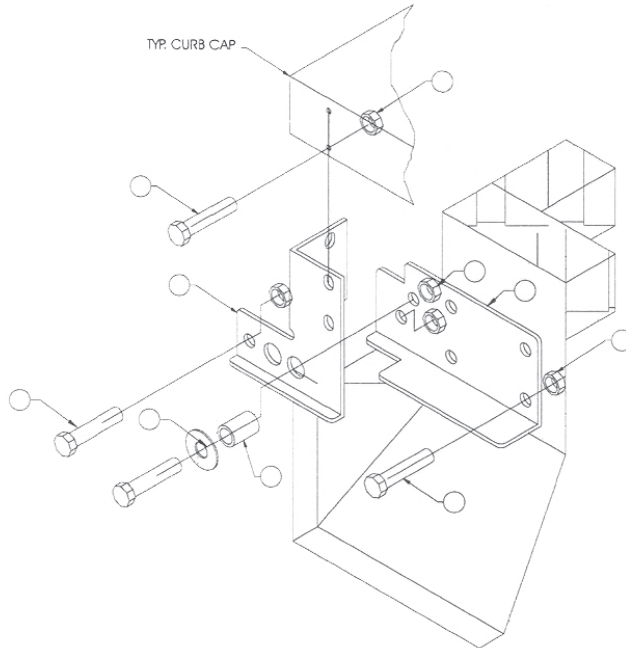

ITEM #	PART #	DESCRIPTION	QTY	ITEM #	PART #	DESCRIPTION	QTY
1	634012	3/8" Flat Washer	2	6	90005802	Hinge Bracket Left Half	1
2	634025	3/8-16 Loknut	2	7	90005101	Curb Hinge Bracket Right	1
3	603656	3/8 x 1-1/4" Long Spacer	2	8	634002	5/16-18 x 3/4 Hex Bolt	16
4	634138	3/8-16 x 2" Long Bolt	4	9	634027	5/16-18 Flange Nut	16
5	90005702	Hinge Bracket Right Half	1	10	90005201	Curb Hinge Bracket Left*	1
				11	634028	1 3/8-16 Flange Nut	2

\*Items on opposite side, not shown

**Note:** Curb cap needs to be 1/2" minimum larger than the roof curb or roof curb adaptor to allow for bolt head clearance and curb cap tilting around the roof curb or roof curb adaptor.

1. With fan in place on roof curb, locate the hinge cap on both end, mark the holes for 5/16" diameter bolts, drill (8) 1 1/32" diameter holes at the marked locations.
2. Attach the hinge cap (items 6 & 7 ) to curb cap or fan using (8) 5/16" bolts & flanged nuts, locate bolt head on the inside of the curb cap.
3. With unit in place on roof curb, align curb hinge on roof curb or curb cap adaptor as shown and mark the (8) locations in the roof curb or curb adaptor\*\*.
4. Drill (8) 1 1/32" diameter holes in previously marked hole locations.
5. Attach curb hinge to roof curb using (8) 5/16" diameter bolts.
6. You can now tilt the fan open about 60°, use the 3/8" bolt to lock the fan in place and prevent it from tipping or slamming shut.
7. Remove the locking bolt when closing back the fan in place, store the bolt next to the fan for future openings or locks.

**CAUTION:** Make sure to remove grease box (if applicable) when tilting the fan to prevent any spillage.

\*\* Two hinge pivot holes are provided in the curb hinge to allow the curb hinge to be mounted higher or lower on the roof curb as required.

# BACKDRAFT DAMPER FOR ROOF MOUNTED AND INLINE CENTRIFUGAL/PROPELLER EXHAUST FANS



6393 Powers Avenue  
Jacksonville, Florida 32217-2298  
P: 904.731.4711 / F: 904.737.8322  
www.jencofan.com

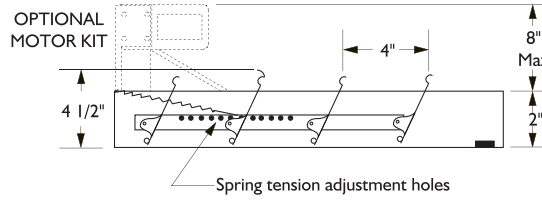
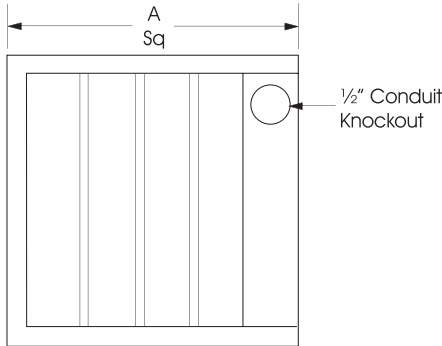

AIR FLOW ↑

**CAUTION:** Motor kits are not suitable for use in explosive or flammable areas or airflows.

For low velocity (CFM) field adjustment of spring tension may be required to ensure that damper blades open completely.

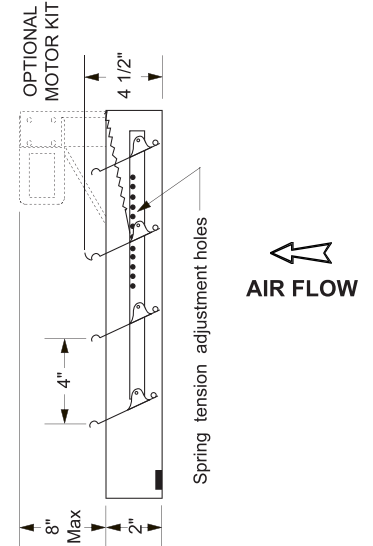

AIR FLOW ←

FAN SIZE	CENTRIFUGAL ROOF FANS	INLINE FANS		PROPELLER
	DB, RED, TXB, LPD, TXD	SQB	SQD	ARE
	"A" SQUARE	"A" SQUARE	"A" SQUARE	"A" SQUARE
6	11	-	9	-
7	-	12	-	-
8	11	12	12	-
9	11	-	-	-
10	11	14	14	14
11/12	18	18	16	18
14	18	-	-	-
15	18	22	20	-
16	18	-	-	22
18	24	24	-	-
20	24	28	-	26
24	30	35	-	-
30	36	40	-	-
36	36	48	-	-
42	48	54	-	-
48	48	-	-	-

**STANDARD SPECIFICATIONS:**

Maximum Face Velocity: 1000 fpm.  
Dimensions: See sizing chart  
"A" Dimension is square damper size.  
Frame: 19 Ga galvanized steel.  
Blades: 26 gauge aluminum.  
Blade pivots: Stainless steel rivet at all pivot points.  
Seals: Felt between adjacent blades.  
Counter Balance: Adjustable spring tension.  
Finish: Mill.  
Max Temp: Damper 250° F  
Motor 130° F

**CAUTION:** Motor kits are not suitable for use in explosive or flammable areas or airflows.

**NOTES:**

- (1) Units are undersized 1/4" to fit in square ducts.
- (2) Do not mount fan less than 1/3 diameter of the fan from the damper.
- (3) Dampers shipped in individual cartons.
- (4) Motor kits ship loose for field installation.

ACCESSORY ITEMS	1	2	3	4	5	ACCESSORY ITEMS	1	2	3	4	5
<input type="checkbox"/>						<input type="checkbox"/>					
<input type="checkbox"/>						<input type="checkbox"/>					
<input type="checkbox"/>						<input type="checkbox"/>					
<input type="checkbox"/>						<input type="checkbox"/>					
<input type="checkbox"/>						<input type="checkbox"/>					

Project: \_\_\_\_\_ Submitted: \_\_\_\_\_  
Customer: \_\_\_\_\_ Approved: \_\_\_\_\_  
Location: \_\_\_\_\_