

JencoFan

Models eGED/eGSD

Installation, Operation, and Maintenance Manual

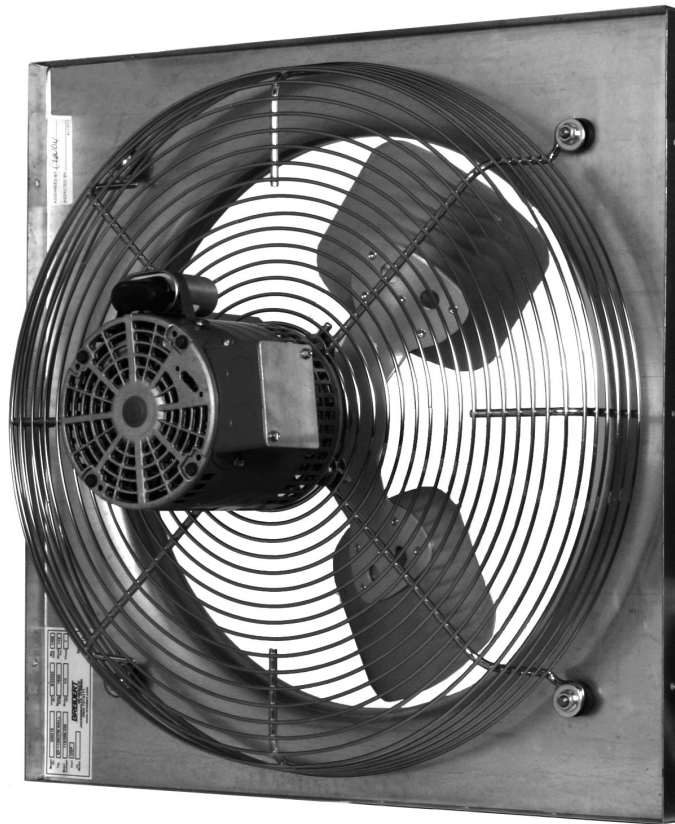

Direct Drive Sidewall Propeller Fans (Exhaust and Supply)

READ AND SAVE THESE INSTRUCTIONS

The purpose of this manual is to aid in the proper installation and operation of fans manufactured by JencoFan. These instructions are intended to supplement good general practices and are not intended to cover detailed instruction procedures, because of the wide variety and types of fans manufactured by JencoFan.

6393 Powers Avenue
Jacksonville, FL 32217
P: 800.961.7370
F: 800.961.7379
eGED/eGSD-v.3_0319



1. WARNINGS

READ AND SAVE THESE INSTRUCTIONS. FAILURE TO COMPLY WITH INSTRUCTIONS COULD RESULT IN PERSONAL INJURY AND/OR PROPERTY DAMAGE!

CAUTION:

- (1) For General Ventilating Use Only. Do Not Use To Exhaust Hazardous Or Explosive Materials And Vapors.
- (2) The eGED/eGSD is suitable for operation within indoor environments only.

WARNING: TO REDUCE THE RISK OF FIRE, ELECTRIC SHOCK OR INJURY, OBSERVE THE FOLLOWING:

1. Use this unit only in the manner intended by the manufacturer. If you have questions, contact the manufacturer.
2. Before servicing or cleaning unit, switch power off at service panel and lock the service disconnecting means to prevent power from being switched on accidentally. When the service disconnecting means cannot be locked, securely fasten a prominent warning device, such as a tag, to the service panel.
3. Installation work and electrical wiring must be done by qualified person(s) in accordance with all applicable codes and standards, including fire-rated construction.
4. Sufficient air is needed for proper combustion and exhausting of gases through the flue (chimney) of fuel burning equipment to prevent back drafting. Follow the heating equipment manufacturer's guideline and safety standards such as those published by the National Fire Protection Association (NFPA), and the American Society for Heating, Refrigeration and Air Conditioning Engineers (ASHRAE), and the local code authorities.
5. When cutting or drilling into wall or ceiling, do not damage electrical wiring and other hidden utilities.
6. Ducted fans must always be vented to the outdoors.

2. PRE-INSTALLATION INSPECTION

The eGED/eGSD has been manufactured in accordance with rigorous standards of production. All the components have been checked and tested at the end of the manufacturing process. We recommend that you check the following after receiving this product:

1. The correct size has been received.
2. The correct model has been received.
3. The details on the rating label correspond to the electrical supply: voltage, frequency etc.

Remove the unit from packaging and inspect for shipping damage within 15 days of receipt. If the product is found to be damaged, immediately contact your local authorized supplier. **DO NOT OPERATE THE UNIT IF DAMAGED.** These instructions should be considered as a supplement to EPA standard practices, as well as all state and local building code regulations. Before installing the product check that there are no obstructions to the airflow.

If you receive damaged goods, contact your JencoFan representative for repair or replacement service.

3. HANDLING

Handle your equipment with caution. Some fans are provided with lifting lugs or holes for easy handling. Others must be handled using nylon straps that protect the fan's coating and housing. Spreader bars should be used when lifting large parts.

Fans should be lifted by using straps around the fan housing only. **DO NOT LIFT FANS BY THE MOTOR, BASE, PROP, OR FLANGES.**

4. STORAGE

If fans are stored for any length of time, they should be stored in a clean, dry location to prevent rust and corrosion. Outdoor storage is not recommended. When outdoor storage is necessary, they should be protected from the elements as best as possible. Cover the fan inlet and outlet and keep motors dry and clean.

For extended storage (more than 3 months), motor shafts should be rotated monthly. Storage records should be kept to assure proper maintenance. The factory can advise warranty centers to provide motor and bearing service if needed.

5. INSTALLATION

Fans mounted off ground level should be rigidly mounted to a special platform and be placed as near as possible to, or over, a solid wall or column.

JencoFan

Supports for suspended fans must be crossbraced for live load support to prevent side sway.

Use guy wires to help secure root units if excessively windy conditions prevail.

1. **CAUTION!** This fan contains rotating parts and requires special service. Appropriate safety precautions should be taken during installation, operation and maintenance.
2. **WARNING!** Do not install or operate this fan in an environment or atmosphere where combustible or flammable materials, gasses or fumes are present, unless it was specifically designed and manufactured for use in that environment. Explosion or fire can result. Explosive, corrosive, high temperature, etc. conditions may require special construction, inspection and maintenance. It is necessary to observe the fan manufacturer's recommendations and limitation concerning the type of material to be handled by the fan and its application in special conditions.
3. A damper, if used, should be securely mounted within the curb or wall in a manner that allows free and unobstructed operation.
4. **CAUTION!** All electrical work must be done in accordance with local and/or national electrical codes as applicable. If you are unfamiliar with methods of installing electrical wiring, secure the services of a qualified electrician.
5. **WARNING!** This product must be grounded.
6. **DANGER!** Make sure power is turned off and locked in the **OFF** position at the service entrance before installing, wiring or servicing fan.
7. **CAUTION!** Before wiring the motor, check the supply voltage against the motor nameplate voltage. High or low voltage can damage the motor and void the motor warranty.
8. **WARNING!** Be sure to keep all wiring clear of rotating or moving parts.
9. **WARNING!** Before starting the fan, turn the propeller to assure it rotates freely. If needed, adjust the propeller/shaft/motor position as required to achieve necessary clearances.
10. **WARNING!** Check all setscrews and keys. Tighten as necessary prior to fan startup.
11. Due to the general nature of its applications, the basic air mover is available with protective guards and/or other devices for required operating safety as with most installations of rotating machinery. Before operating the basic unit in any of its applications determine requirements for such guards and/or devices needed for protection against accidental contact with moving parts or against injury to nearby personnel or critical equipment due to accidental rupture of fast moving parts.

6. START-UP

Lock out the power source.

Tighten all bolts and setscrews securely. **NOTE THAT ALL BOLTS AND SETSCREWS SHOULD BE TIGHTENED AFTER TWO DAYS OF INITIAL OPERATION.**

Clearance should be checked all around between propeller tips and the housing before starting up. The propeller should not strike the housing.

No initial lubrication is required. Motors have been pre-lubricated by motor manufacturer.

Arrows to show direction of rotation and airflow are attached to the fan housings.

After the electrical connections are completed, apply just enough power to start the impeller as indicated by the directional arrows on the unit. If the impeller is turning the wrong direction, it will not deliver rated airflow and the motor connections must be altered to correct rotation.

Lock out the power source before the installation of all accessories.

Fan electrical power can now be applied and special attention should be given to determine if motor is working properly. At this time, with air system in full operation, with guards attached, it is well for the electrician to measure the operating amperage of the motor and compare with the nameplate rating to determine that the motor is operating under safe load conditions.

The fan should not need balancing, as it was balanced at the factory to meet stringent vibration levels before shipment. However, there are several things that may cause vibration, such as rough handling in shipment and erection, weak foundations, and alignments.

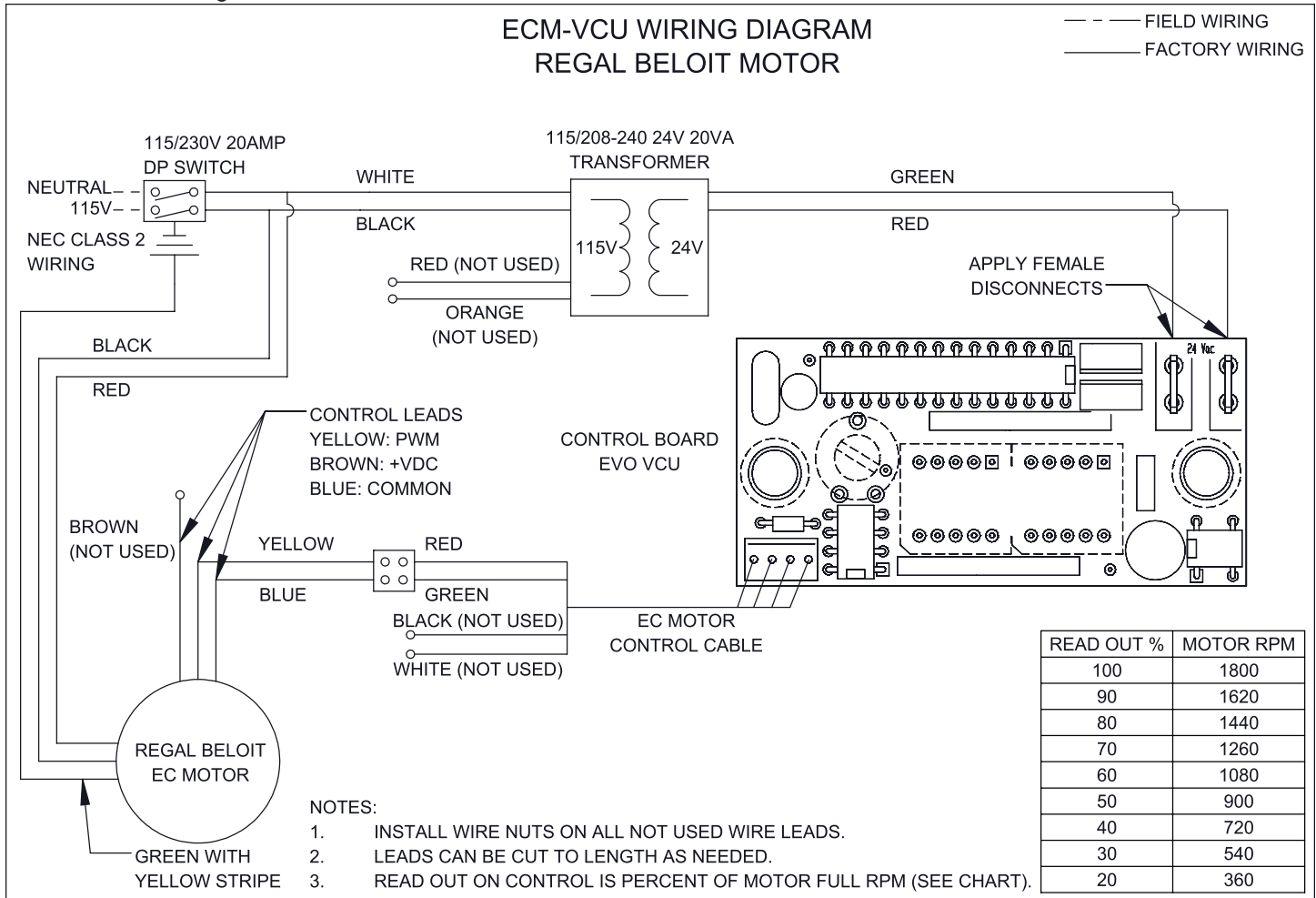

7. MAINTENANCE

- Before performing any maintenance on the fan, be sure power is turned off and locked in the OFF position at the service entrance before servicing the fan.
- Ventilators should be carefully checked at least once a year. For critical or rugged applications, a routine check every two or three months is suggested.
- All motors supplied with JencoFan ventilators carry a one (1) year warranty from date of shipment. For repairs within the warranty period, the motor must be taken to the motor manufacturer's authorized service dealer. Contact your representative for additional warranty details.
- A periodic motor check should consist of spinning the motor shaft with the power off to be sure the motor turns freely.
- Check sheave set screws to ensure tightness. Proper keys must be in keyways.
- Do not readjust blade pitch or fan RPM. If sheaves are replaced, use only sheaves of identical size and type.
- During the first few months of operation, it is recommended that the setscrews be checked to assure they are tight.

8. The rotating propeller requires particular attention in most applications since materials in the air being handled can build up on the blades to cause destructive vibration; and may also corrode and/or erode the blade metal to weaken the structure of the propeller. Regular inspection and corrective action at intervals determined by the severity of each application are essential to good service life.

8. MOTORS

The fundamental principle of electrical maintenance is **KEEP THE MOTOR CLEAN AND DRY**. This requires periodic inspection of the motor. The frequency depends upon type of motor and the service.

We recommend periodic checks of voltage, frequency, and current of a motor while in operation. Such checks assure the correctness of frequency and voltage applied to the motor, and yield an indication of the fan load. Comparison of this data with previous data will give an indication of the fan performance. Any serious deviations should be investigated and corrected.

Lubricate integral horsepower motors per the motor manufacturer's recommendations. Lubrication frequency depends on the motor horsepower, speed, and service. Use compatible greases.

1. All motors carry a one (1) year warranty from date of shipment. For repairs within the warranty period, the motor must be taken to the motor manufacturer's authorized service dealer. Contact your representative for additional warranty details.
2. A periodic motor check should consist of spinning the motor shaft with the power off to be sure the motor turns freely.

9. REPAIR PARTS

1. Fan Blades – Repair of individual fan blades or propeller assemblies is not recommended. Contact factory with blade size, number of blades, bore size, motor HP, air flow direction, rotation, fan RPM or sheave sizes and any order/tag information that is available for replacement.
2. Misc. Parts – Not available from local trade channels should be returned for repair or replacement. Be sure to obtain return tags or authorization before shipment.
3. Electric Motors – Repair or replacement of motors is normally performed by a repair station authorized by the manufacturer. Contact your representative or the factory for locations nearest to you. **DO NOT** ship motor to the factory without specific authorization.

10. FAN TROUBLE-SHOOTING CHART



PROBLEM	POSSIBLE CAUSES
Excessive Vibration	Propeller loose on shaft Out of balance propeller Excessive buildup of dirt/dust on propeller Bent shaft Weak mounting base for fan Fan mounting bolts loose Loose or worn motor bearings Structures not crossbraced (wall fans)
Excessive Horsepower	Static pressure higher than design Propeller rotating in wrong direction Fan speed higher than design
Too Little Air	Restricted fan inlet or outlet Propeller rotating in the wrong direction System is more restrictive (more static pressure) than expected Fan speed lower than design Inlet or Outlet screens clogged
Too Much Air	Fan speed higher than design System is less restrictive (less static pressure) than expected
Fan Does Not Operate	Wrong voltage Electricity turned off or note wired properly Blown fuses Overload protector has broken circuit
Excessive Noise	Propeller loose Accumulation of material on propeller Worn or corroded propeller Propeller out of balance Propeller hitting housing Bent shaft Loose fan mounting bolts Rattle of components in high velocity airstream Electrical noise Noise from high velocity air system Vibrating parts not isolated from building Vibrating duct work

11. WARRANTY

JencoFan warrant that the eGED/eGSD will be free from defective materials and workmanship for the period of (5) years from the date of original purchase. In the event that we find any part is defective the product will be repaired or, in the Company's discretion, replaced without charge provided that the product has been installed in accordance with the enclosed instructions and all applicable EPA Standards and state and local building codes.

IF CLAIMING UNDER WARRANTY: Please return the complete product, freight paid, to your local authorized distributor. All returns must be accompanied by a valid Bill Of Sale. All returns must be clearly marked "Warranty Claim," with an accompanying description stating the nature of the fault. THE FOLLOWING WARRANTIES DO NO APPLY: Damages from shipping, either concealed or visible. Claim must be filed with the carrier. Damages resulting from improper wiring or installation Damages caused by acts of nature, or resulting from improper consumer procedures such as: Improper Maintenance; Misuse; Negligence; Alteration; Abuse; Abnormal Use; or Accident or Incorrect Electrical Voltage and Current. Removal or alteration to the JencoFan data plate label.

WARRANTY VALIDATION: The end user must keep a copy of the Bill of Sale to verify purchase date.

JencoFan

THE ABOVE (5) YEAR WARRANTY IS EXPRESSLY IN LIEU OF ALL OTHER WARRANTIES, EXPRESSED, WRITTEN OR IMPLIED, INCLUDING THE WARRANTIES OF MERCHANTABILITY AND FITNESS FOR USE. IN NO EVENT SHALL JENCOFAN BE LIABLE FOR ANY SPECIAL, CONSEQUENTIAL, OR INCIDENTAL DAMAGES, INCLUDING LOSS OF PROPERTY, REVENUES, LOST PROFITS, COSTS OF REMOVAL, INSTALLATION OR REINSTALLATION.

LIMITATION OF WARRANTY AND LIABILITY:

This warranty does not apply to any such JencoFan product or parts which have failed as a result of faulty installation or abuse, or incorrect electrical connections or alterations, made by others, or use under abnormal operating conditions or misapplication of the products and parts.

JencoFan will not approve for payment any repairs made outside the factory without prior written consent of its Jacksonville, Florida office.

The foregoing shall constitute our sole and exclusive warranty and our sole and exclusive liability and is in lieu of all other warranties, whether written, oral, implied or statutory. There are no warranties which extend beyond the description of the page hereof. Seller does not warrant that said goods and articles are of merchantable quality or that they are fit for any particular purpose. The liability of seller on any claim of any kind, including negligence, for any loss or damage arising out of or connected with, or resulting from the sale and purchase of the products and parts covered by this proposal, acknowledgement, order or from the performance or breach of any contract pertaining to such sale or purchase, or from the design, manufacture, sale, delivery, resale, installation, technical direction of installation, inspection, repair, operation or use of any products or parts covered by this proposal, acknowledgement, order or furnished by seller shall, in no case exceed the price allocable to the products or parts thereof which give rise to the claim and shall terminate one (1) year after the shipment of said products and parts.

In no event, whether as a result of breach of contract, or warranty or alleged negligence, defects, incorrect advice or other causes, shall seller be liable for special or consequential damages, including, but not limited to, loss of profits or revenue, loss of use of the equipment or any associated equipment, cost of capital, cost of substitute equipment, facilities or services, down time costs, or claims of customers of the purchaser for such damages. JencoFan neither assumes nor authorizes any persons to assume for it any other liability in connection with the sale of its fan products and parts. Some states do not allow the exclusion or limitation of incidental or consequential damages, so all of the above limitations or exclusions may not apply to you.

SAFETY ACCESSORIES WARNING:

The responsibility for providing safety accessories for equipment supplied by JencoFan is that of the installer and user of this equipment. JencoFan sells its equipment with and without safety accessories, and accordingly it can supply such safety accessories upon receipt of order.

The user, in making its determination as to the appropriate safety accessories to be installed and any warning notices, should consider (1) the location of the installation, (2) the accessibility of employees and other persons to this equipment, (3) any adjacent equipment, (4) applicable building codes, and (5) requirements of the Federal Occupational Safety and Health Act. Users and installers of this equipment should read "RECOMMENDED SAFETY PRACTICES FOR AIR MOVING DEVICES" which is published by Air Movement and Control Association, 30 West University Drive, Arlington Heights, Illinois 60004.

JencoFan

USA Division

6393 Powers Avenue
Jacksonville, FL 32217
P. 904-731-4711 · F. 904-737-8322
www.jencofan.com

Canada Division

6710 Maritz Drive Unit #7
Mississauga, ON L5W 0A1 - Canada
P. 416-744-1217 · F. 416-744-0887
www.jencofan.com

