

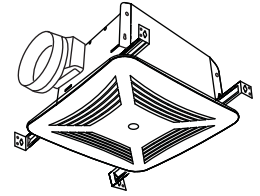

# VENTILATION FAN



Model: PCD110XMH

## WARNING

**WARNING -TO REDUCE THE RISK OF FIRE, ELECTRIC SHOCK, OR INJURY TO PERSONS, OBSERVE THE FOLLOWING:**

- a). Use this unit only in the manner intended by the manufacturer. If you have questions, contact the manufacturer.
- b). Before servicing or cleaning unit, switch power off at service panel and lock the service disconnecting means to prevent power from being switching on accidentally. When the service disconnecting means cannot be locked, securely fasten a prominent warning device, such as a tag, to the service panel.
- c). Installation work and electrical wiring must be done by a qualified person(s) in accordance with all applicable codes and standards, including fire-rated construction codes and standards.
- d). Sufficient air is needed for proper combustion and exhausting of gases through the flue (chimney) of fuel burning equipment to prevent backdrafting. Follow the heating equipment manufacturer's guideline and safety standards such as those published by the National Fire Protection Association (NFPA), and the American Society for Heating, Refrigeration and Air Conditioning Engineers (ASHRAE), and the local code authorities.
- e). When cutting or drilling into wall or ceiling, do not damage electrical wiring and other hidden utilities.
- f). Ducted fans must always be vented to the outdoors.
- g). Acceptable for use over a tub or shower when connected to a GFCI (Ground Fault Circuit Interrupter) - protected branch circuit (ceiling installation only).
- h). This unit must be grounded.
- i). Not for Use in Kitchens.
- j). Install Fan At Least 2.5 m (8.2 feet) Above The Floor.
- k). To reduce risk of fire and to properly exhaust air, be sure to duct air outside – Do not vent exhaust air into spaces within walls or ceilings or into attics, crawl spaces, or garages
- l). **WARNING: To Reduce The Risk Of Fire Or Electric Shock, Do Not Use This Fan With Any Solid-State Speed Control Device.**
- m). The fan must not be installed in a ceiling thermally insulated to a value greater R40

## CAUTION

- 1. For general ventilating use only. Do not use to exhaust hazardous or explosive materials and vapors.
- 2. This product is designed for installation in ceilings up to a 12/12 pitch (45 degree angle). Duct connector must point up. **DO NOT MOUNT THIS PRODUCT IN A WALL.**
- 3. To avoid motor bearing damage and noisy and/or unbalanced impellers, keep drywall spray, construction dust, etc. off power unit.
- 4. Please read specification label on product for further information and requirements.  
\*The manual in electronic format can be download in our company web, or obtained from our dealer.

## CLEANING & MAINTENANCE

For quiet and efficient operation, long life, and attractive appearance - lower or remove grille and vacuum interior of unit with the dusting brush attachment.  
The motor is permanently lubricated and never needs oiling. If the motor bearings are making excessive or unusual noises, replace the motor with the exact service motor. The impeller should also be replaced.

## OPERATION

- The control box, located inside the fan housing, has three separate adjustments:
- (1) The low airflow knob adjusts the lower airflow from 40CFM up to the air flow rate of the high fan speed determined by the toggle switch setting.
  - (2) The Humidity Sensor Knob set user adjustable setpoint (50%-100% relative humidity).
  - (3) The toggle switch will adjust the upper fan speed setting from 90 to 140 CFM .

Switch position				
Airflow (CFM)	90	110	120	140
Duct diameter (inches)	6"	6"	6"	6"

■ is the position of switch  
Factory setting: 110CFM (with 6" duct )  
HVI Certified performance based on HVI Procedures 915, 916, and 920.

**READ AND SAVE THESE INSTRUCTIONS**  
Installer: Leave this manual with the homeowner.

# OPERATION

## MOTION SENSOR

Turn on the switch to activate sensor and continuous ventilation system. The fan will run continuously at the pre-set low speed. When motion is detected, the fan speed increases to high speed. When the person exits the area, the fan remains working at high speed until the delay time has passed (20 minutes). After the time delay, the fan speed is reduced to the continuous ventilation rate.

Installation distance: 7 to 9 feet.

Sensing range is within the cone angle of 90°

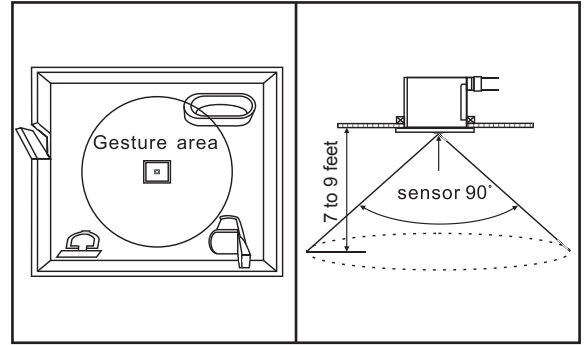

## HUMIDITY SENSOR OPERATION

The humidity-sensing fan use a sophisticated humidity sensor that responds to: (a) rapid to moderate (user-adjustable) increases in humidity or (b) humidity above a user-adjustable set-point (50%-100% relative humidity). Fan run continuously, at a preset lower level (set by Humidity sensor knob) and automatically boost up to certified airflow rate when environmental conditions change. After delay timer ( 20 minutes) returns fan to the default low speed. If the fan continuously responds to changing environmental conditions, "H"(means "humidity") adjustment may be required. This figure is factory-set for about 75% (Ambient temperature of 25 °C).

## SENSITIVITY ADJUSTMENT

The "H" has been factory set for most shower applications. However, if the fan is in a tub area or is being used for dampness control, the "H" may need to be increased toward maximum "+". If the control is responding too often to changing environmental conditions, movement toward less "-" "H" may be required.

To adjust the "H":

1. Disconnect power at service entrance.
2. Through the grille, locate the slot marked "H".
3. Carefully rotate the "H" adjustment toward "+" or "-".
4. Turn on power and check operation by turning on the shower or other humidity source until the fan turns on.
5. Repeat above steps if necessary.

When the temperature changes, humidity sensor values will have deviation.

# PLAN THE INSTALLATION

1. Do not use in a cooking area.
2. Two ways to connect ductwork to a factory-shipped unit.

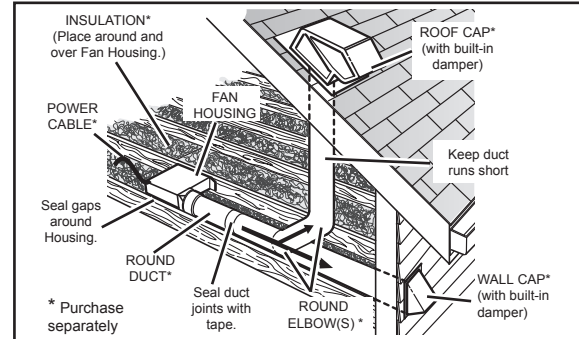
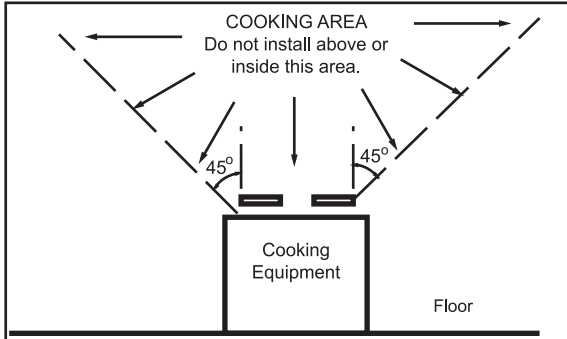

# TYPES OF TYPICAL INSTALLATIONS

1. Housing mounted to I-joists (Start at "ASSEMBLY INSTRUCTIONS 1")
2. Housing mounted to joists (Start at "ASSEMBLY INSTRUCTIONS 1" )
3. Housing mounted to truss (Start at step "ASSEMBLY INSTRUCTIONS 2")

# ASSEMBLY INSTRUCTIONS

## 1. MOUNT HOUSING TO JOIST OR I-JOIST.

Hold the housing so that it is in contact with the bottom of the joist. Attach the housing with four (4) screws to the joist through the holes in each mounting flange.

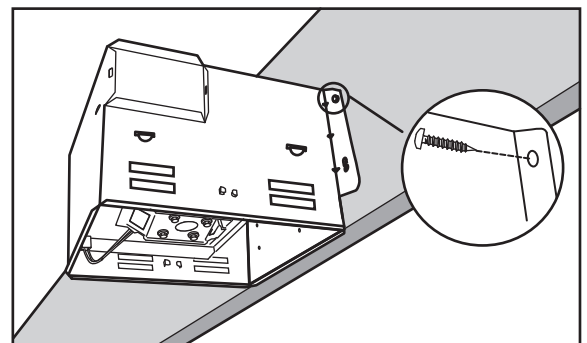

# ASSEMBLY INSTRUCTIONS

## 2. MOUNT WITH HANGER BARS

2a. Sliding hanger bars have been provided, which allow the housing to be positioned accurately anywhere between the framing. The bars span up to 24 in. and can be used on all types of framing: I-joist, standard joist, and truss construction. Slide hanger bars onto housing and adjust as needed to fit between framing.

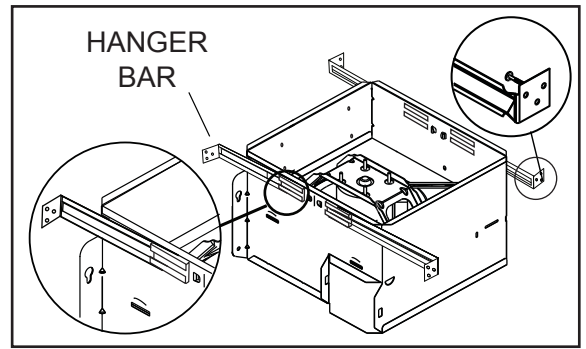

2b. Extend the hanger bars to the width of the framing. Position the ventilator with the hanger bar tabs wrapped around the bottom edge of the framing, holding the ventilator in place. Secure hanger bars to framing using one screw on each end of hanger bar. Select a proper hole and secure the hanger bars together using flange screws.

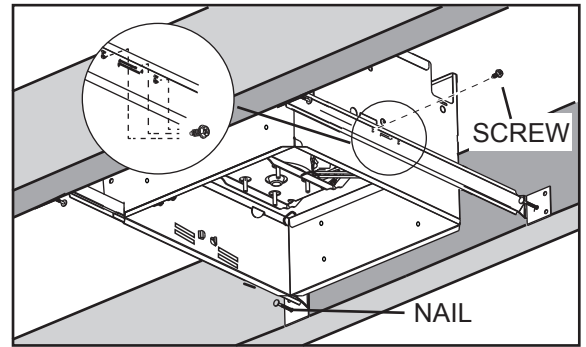

## 3. ATTACH DAMPER/DUCT CONNECTOR

Snap the damper/duct connector onto the fan housing. The connector must be flush with the top of the housing, and the damper flap should fall closed.

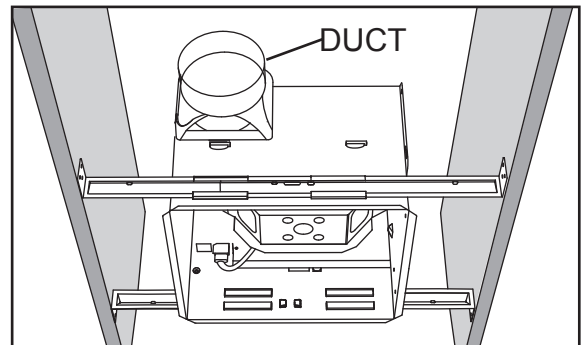

Insulated flexible duct is recommended for the quietest possible installation. If rigid duct is used, a short (1-3 feet) section of insulated flexible duct will ensure quiet operation

## 4. INSTALL ROUND DUCTWORK

Connect the round ductwork (not included) to the damper/duct connector, and run the ductwork to a roof or wall cap (not included). Using tape (not included), secure all the ductwork connections so that they are air tight.

The ducting from this fan to the outside of building has a strong effect on the air flow, noise and energy use of the fan. Use the shortest, straightest duct routing possible for best performance, and avoid installing the fan with smaller ducts than recommended. Insulation around the ducts can reduce energy loss and inhibit mold growth. Fans installed with existing ducts may not achieve their rated air flow.

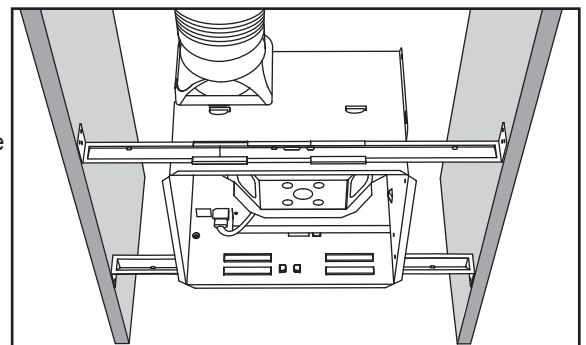

# CONNECT ELECTRICAL WIRING

Run 120 V AC house wiring to the location of the fan. Use only UL-approved connectors (not included) to attach the house wiring to the wiring plate. Refer to the wiring diagram, and connect the wires as shown.

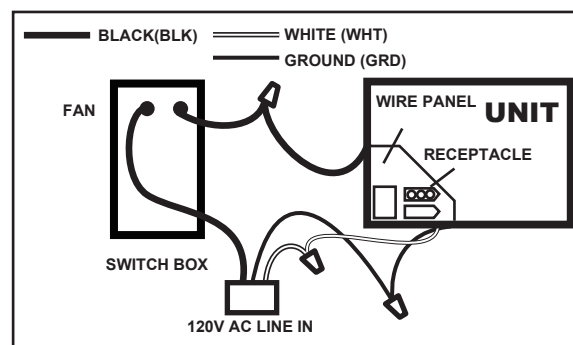
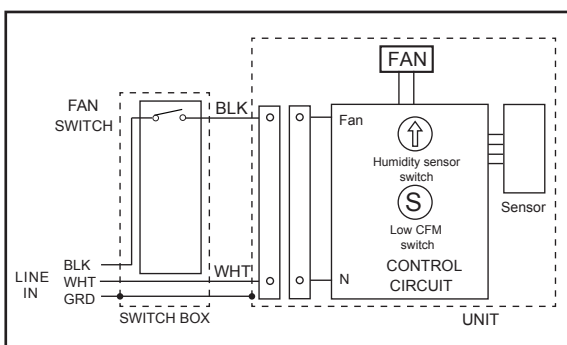

## INSTALL GRILLE

Install ceiling material to complete the ceiling construction. Then, cut around the fan housing.

First insert the sensor plug into the plug base on the power box, and then install the grille.

To attach the grille assembly to the fan housing, pinch the grille springs on the sides of the grille assembly, and position the grille into the housing with the grille springs in the appropriate slots. Push the grille assembly towards the ceiling to secure.

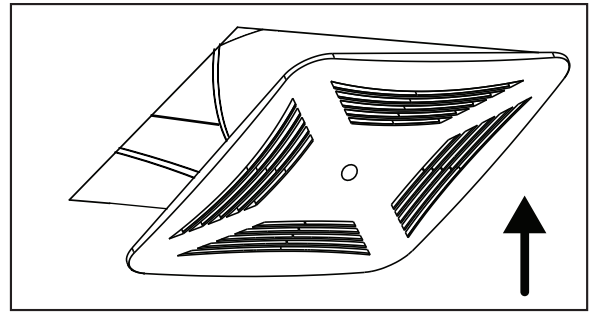

## SERVICE PARTS

PART	PART NAME	Qty.
1	Grille Assembly (includes part 2 & 12)	1
2	Grille Spring	2
3	Power Box	1
4	Motor Plate	1
5	Motor	1
6	Blower Wheel	1
7	Wire Panel / Harness Assembly	1
8	Wiring plate	1
9	Housing	1
10	Hanger Bar Kit	4
11	Damper / Duct Connector	1
12	Sensor	1
a	Nut, Hex Lock	4
b	Washer	4
c	Screw	1
d	Isolator	4
e	Screw	1

\* Blower Assembly includes part 6, 5, d, 4, c, b, a.

Replacement installation:

Remove the screw (part c), then take out the motor plate (part 4) from the housing (part 9) by pushing down the rib in the plate while pulling out on the side of the housing. Replace the broken parts.

**WARNING:** Before replacing, be sure to turn off power at power source.

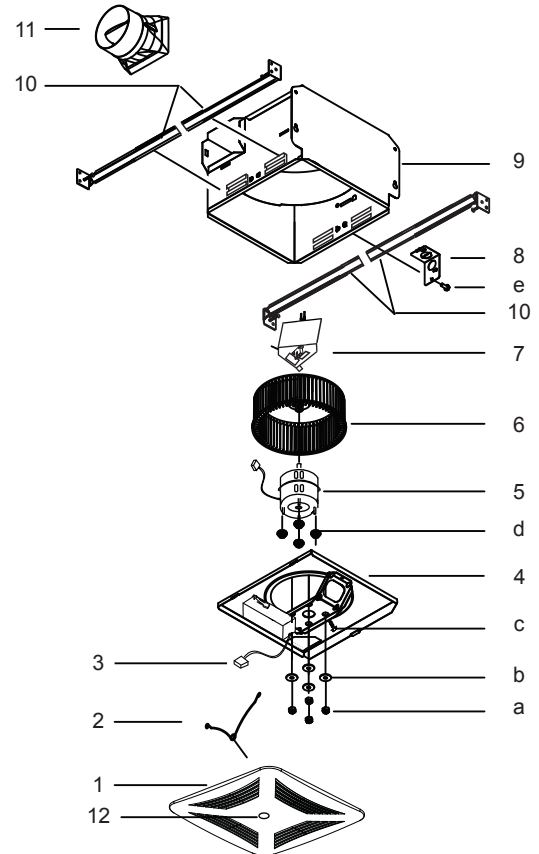

## WARRANTY

S&P USA Ventilation Systems, LLC. & S&P Canada Ventilation Products, Inc. warrants to the original end user of its products that our exhaust fans will be free from defects in materials and workmanship for a period of Five (5) years from the date of original purchase. 6 years warranty for motor and 5 years warranty for the remaining fan parts. THERE ARE NO OTHER WARRANTIES, EXPRESSED OR IMPLIED, INCLUDING BUT NOT LIMITED TO IMPLIED WARRANTIES OF SUITABILITY FOR A PARTICULAR PURPOSE.

During this five year period, S&P will, at its option, repair returned products or parts, or provide replacement products or parts, without charge, for any product or part which is found to be defective under normal use.

This warranty does not cover normal maintenance and service or any parts that have been subject to misuse, negligence, accident, improper maintenance or repair, faulty installation or installation contrary to recommended installation instructions. S&P's obligation to repair or replace, at S&P's option, shall be the purchaser's sole and exclusive remedy under this warranty. No labor or materials are covered by this warranty. S&P shall not be liable for incidental damages arising out of or in connection with product use or performance.

This warranty gives you specific legal rights. You may also have other rights which vary from state to state.

To qualify for warranty service, you must notify S&P at the address or telephone number stated below, provide the model number and part identification, and describe the nature of any defect in product or part. You may be required to ship a defective part to S&P. There will be no charge for shipping repaired or replacement parts from S&P to you if your address is in the United States or Canada. At the time of requesting warranty service, you must present evidence of the original purchase date.

### S&P USA Ventilation Systems, LLC.

6393 Powers Avenue Jacksonville, FL 32217  
P. 904-731-4711  
F. 904-731-8322  
www.spvg-northamerica.com

### S&P Canada Ventilation Products, Inc.

5600 Ambler Drive Mississauga, ON L4W 2K9  
P. 866-733-0233  
F. 866-358-5346  
www.solerpalaucaCanada.com