

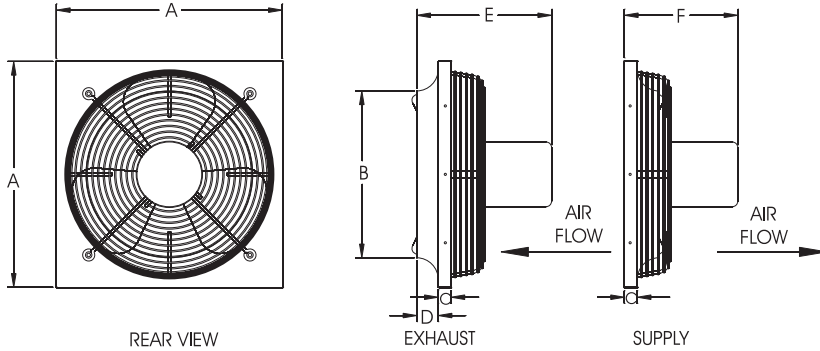

MODEL eGED/eGSD SIDEWALL PROPELLER FANS WITH EC MOTORS

STANDARD CONSTRUCTION FEATURES

- Galvanized steel G90 panel assembly.
- Statically and dynamically balanced aluminum blades.
- Integral OSHA approved motor side guard.
- One piece spun venturi for maximum efficiency.
- Pre-punched mounting holes for easy installation.
- Unit suitable for all-angle construction.
- AMCA Air and Sound Licensed
- cULus Listed - Standard 705



Size	Dimensions (in.)						Avg. Ship Wt. (lbs.)
	A	B	C	D	E*	F*	
12	16	12-1/2	1	2	14	12	30
14	20	14-1/2	1	2	14	12	34
16	20	16-1/2	1	2	14	12	37
18	24	18-1/2	1	2	15	13	45
20	24	20-1/2	1	2	15	13	50



- A. Outside dimension of square panel.
 B. Diameter of venturi.
 C. Width of flange, 1" for all models.
 D. Depth of venturi, 2" for all models.
 E. Depth of fan (exhaust).
 F. Depth of fan (supply).

* Varies with motor selection.

FAN SPECIFICATIONS									MOTOR SPECIFICATIONS				
Line	Qty.	Model No.	Tag	CFM	SP	Fan RPM	BHP	Sones	HP	Volts	Phase	Hertz	Encl
1													
2													
3													
4													
5													

ACCESSORY ITEMS					1	2	3	4	5	ACCESSORY ITEMS					1	2	3	4	5
<input type="checkbox"/>										<input type="checkbox"/>									
<input type="checkbox"/>										<input type="checkbox"/>									
<input type="checkbox"/>										<input type="checkbox"/>									
<input type="checkbox"/>										<input type="checkbox"/>									
<input type="checkbox"/>										<input type="checkbox"/>									

Project: _____ Submitted: _____
 Customer: _____ Approved: _____
 Location: _____