

### STANDARD FEATURES

(For STXB, STXB-HP, STXB-W, and STXB-RHUL and their variants)

- Attractive spun aluminum exterior
- Belt drives permit easy performance adjustments when needed
- Curved non-overloading backward inclined wheel for efficiency at higher static pressures
- Conduit provided through base of unit for electrical connection
- AMCA Air and Sound Licensed
- NFPA - suitable for National Fire Protection Association Installations
- cULus 705

### STXB-W FEATURES

- Sizes 8-24 are wall mount capable
- Roof or sidewall mounting options
- cULus 705 or 762

### STXB-RHUL FEATURES

- For restaurant exhaust
- Galvanized steel base
- Electrical connection located on shroud side with weather proof junction box
- cULus 762

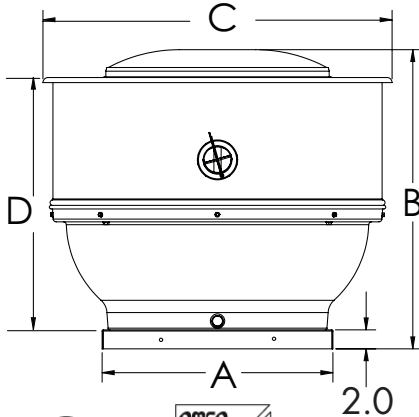

NOTE: All dimensions shown are in inches.

Size	DIMENSIONS							
	A	B	C	D	Roof Opening	Curb (O.D.)	Damper (O.D.)	Average Ship Wt. Lbs.
8	18	29 5/16	28 5/8	24 5/16	13 1/2	16 1/2	12	74
10	18	29 5/16	28 5/8	24 5/16	13 1/2	16 1/2	12	74
12	20	30 7/8	31 5/16	25 15/16	15 1/2	18 1/2	14	82
14	20	30 7/8	31 5/16	25 15/16	15 1/2	18 1/2	14	89
15	24	31 1/2	36 1/2	26 5/8	19 1/2	22 1/2	18	98
16	24	31 1/2	36 1/2	26 5/8	19 1/2	22 1/2	18	99
18	30	35 3/4	42 5/8	30 1/2	25 1/2	28 1/2	24	143
20	30	38 5/8	46 7/16	30 1/2	25 1/2	28 1/2	24	146
22	30	38 5/8	46 7/16	33 5/16	25 1/2	28 1/2	24	146
24	36	49 1/8	50 1/2	37 1/2	31 1/2	34 1/2	30	199
27	36	51 5/8	61 5/16	41 1/2	31 1/2	34 1/2	30	227
30	42	52 5/16	65 7/16	42 1/4	37 1/2	40 1/2	36	301
33	42	52 5/16	65 7/16	42 1/4	37 1/2	40 1/2	36	303
36	42 5/16	50 11/16	64 1/4	44 1/4	37 1/2	40 1/2	36	357
42	54 1/4	56 15/16	76 1/8	48 3/16	49 1/2	52 1/2	48	512
48	54 1/4	60 3/16	80 7/8	52 3/8	49 1/2	52 1/2	48	553

\*Approximate unit weight includes the largest cataloged open drip proof motor, drives (if applicable), less crating.

FAN SPECIFICATIONS									MOTOR SPECIFICATIONS				
Line	Qty.	Model No.	Tag	CFM	SP	Fan RPM	BHP	Sones	HP	Volts	Phase	Hertz	Encl
1													
2													
3													

ACCESSORY ITEMS					ACCESSORY ITEMS						
	1	2	3	4	5		1	2	3	4	5
<input type="checkbox"/>						<input type="checkbox"/>					
<input type="checkbox"/>						<input type="checkbox"/>					
<input type="checkbox"/>						<input type="checkbox"/>					